

# Axial piston variable pump

## A4CSG Series 3x

**RE 92105**

Edition: 12.2016

Replaces: 07.2016

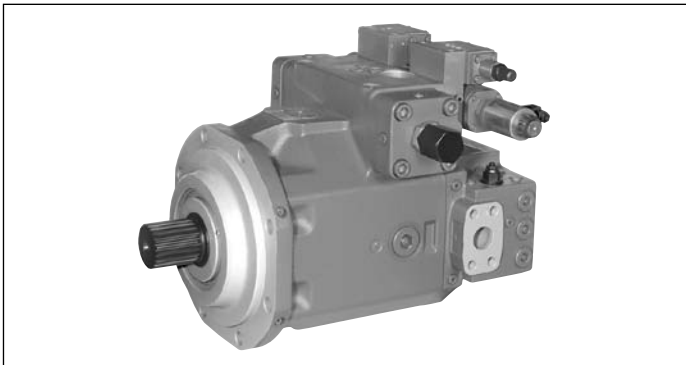

- ▶ Sizes 250 to 750
- ▶ Nominal pressure 350 bar
- ▶ Maximum pressure 400 bar
- ▶ Closed circuit

### Features

- ▶ Variable pump in axial piston swashplate design for hydrostatic drives in closed circuit.
- ▶ The flow is proportional to the drive speed and displacement.
- ▶ By controlling the swashplate angle, infinitely variable flow is possible.
- ▶ The boost pump required for closed-circuit operation and the corresponding valve technology are integrated in the pump.
- ▶ The integrated boost pump acts as a feed pump and pilot pressure supply.
- ▶ Compact design with extremely short installation length
- ▶ Favorable power/weight ratio
- ▶ Low noise level
- ▶ Long service life
- ▶ High efficiency
- ▶ Electrohydraulic proportional control with neutral position in the event of a power failure
- ▶ Through drive and pump combination also possible with integrated boost pump
- ▶ For descriptions of the control devices, please refer to separate data sheets 92076, 92080, 92084.

### Contents

Type code for standard program	2
Hydraulic fluids	4
Shaft seal	5
Working pressure range	6
Technical data	7
Overview of control devices	9
Dimensions, size 250	12
Dimensions, size 355	14
Dimensions, size 500	16
Dimensions, size 750	18
Through drive	20
Dimensions through drive	22
Integrated boost pump and valve technology	28
External boost pressure supply	30
Filtration types	31
Installation instructions	33
Project planning notes	36
Safety instructions	36



## Type code for standard program

01	02	03	04	05	06	07	08	09	10	11	12	13	14
A4CS	G		/			-	V		35				

### Axial piston unit

01	Swashplate design, variable, nominal pressure 350 bar, maximum pressure 400 bar	A4CS
----	---	------

### Operating mode

02	Pump, closed circuit	G
----	----------------------	---

### Size

03	Geometric displacement, see technical data on page 7	250	355	500	750
----	--	-----	-----	-----	-----

### Control device

04	Control system hydraulic	with control valve	see 92076	●	●	●	○	HS5
		with proportional valve		○	●	●	○	EO2
	Proportional control	hydraulic control, pilot-pressure related	see 92080	●	●	●	●	HD..
		electrohydraulic	see 92084	●	●	●	●	EP..

### Series

05	Standard version	●	●	●	●	30
	Efficiency-optimized version	○	○	●	○	33

### Directions of rotation

06	Viewed on drive shaft	clockwise				R
		counter-clockwise				L

### Sealing material

		250	355	500	750	
07	FKM (fluoroelastomer)	●	●	●	●	V
	NBR (nitrile rubber), shaft seal made of FKM (fluoroelastomer)	○	○	○	○	P

### Drive shaft

		250	355	500	750	
08	Parallel keyed shaft DIN 6885	●	●	●	●	P
	Splined shaft DIN 5480	●	●	●	●	Z

### Mounting flange

		250	355	500	750		
09	Based on ISO 3019-2 (metric)	4-hole	●	●	-	-	B
		8-hole	-	-	●	●	H

### Working port

10	SAE flange ports A and B, positioned laterally opposite each other, metric fastening thread	35
	SAE flange port S, positioned laterally offset from A and B by 90°, metric fastening thread	

### Boost pump

11	With integrated boost pump	●	●	●	●	F
	Without integrated boost pump	●	●	●	●	K

● = Available    ○ = On request    - = Not available

### Notice

► Note the project planning notes on page 36!

01	02	03	04	05	06	07	08	09	10	11	12	13	14
<b>A4CS</b>	<b>G</b>		/			-	<b>V</b>		<b>35</b>				

**Through drive** (for mounting options, see page 23)

		250	355	500	750	
12	With through-drive shaft, without hub, without intermediate flange, closed with cover	●	●	●	●	<b>99</b>
With through drive for mounting a second unit						
Flange ISO 3019-2 (metric)    Hub for splined shaft DIN 5480						
	125, 4-hole                      W32×2×14x9 g	○	●	●	○	<b>31</b>
	140, 4-hole                      W40×2×18x9 g	○	○	●	○	<b>33</b>
	160, 4-hole                      W50×2×24x9 g	●	●	●	●	<b>34</b>
	224, 4-hole                      W60×2×28x9 g	●	○	●	○	<b>35</b>
	224, 4-hole                      W70×3×22x9 g	-	●	●	○	<b>77</b>
	315, 8-hole                      W80×3×25x9 g	-	-	●	○	<b>43</b>
	400, 8-hole                      W90×3×28x9 g	-	-	-	○	<b>76</b>
Flange ISO 3019-2 (metric)    Hub for splined shaft SAE J744						
	80, 2-hole                      3/4 in (19-4)	○	○	○	○	<b>B2</b>
	100, 2-hole                      7/8 in (22-4)	●	●	○	○	<b>B3</b>
	100, 2-hole                      1 in (25-4)	○	○	○	○	<b>B4</b>
	125, 4-hole                      1 in (25-4)	○	○	○	○	<b>E1</b>
	125, 2-hole                      1 1/4 in (32-4)	●	●	○	○	<b>B5</b>
	160, 4-hole                      1 1/4 in (32-4)	○	○	○	○	<b>B8</b>
	125, 2-hole                      1 1/2 in (38-4)	○	●	○	○	<b>B6</b>
	180, 4-hole                      1 1/2 in (38-4)	○	○	○	○	<b>B9</b>
	180, 4-hole                      1 3/4 in (44-4)	○	○	○	○	<b>B7</b>
Flange SAE J744                      Hub for splined shaft SAE J744						
	82-2 (A)                      5/8 in (16-4)	●	●	●	●	<b>01</b>
	82-2 (A)                      3/4 in (19-4)	○	●	●	○	<b>52</b>
	101-2 (B)                      7/8 in (22-4)	●	●	●	○	<b>68</b>
	101-2 (B)                      1 in (25-4)	○	●	●	○	<b>04</b>
	127-2 (C)                      1 1/4 in (32-4)	●	●	●	○	<b>07</b>
	127-4 (C)                      1 1/4 in (32-4)	○	○	○	○	<b>15</b>
	127-2 (C)                      1 1/2 in (38-4)	●	●	●	○	<b>24</b>
	152-4 (D)                      1 3/4 in (44-4)	●	●	●	●	<b>17</b>

**Valves**

13	Boost, control pressure relief and flushing valve integrated; direct operated high-pressure relief valve integrated	○	○	○	○	<b>3</b>
	Boost, control pressure relief and flushing valve integrated; pilot-operated high-pressure relief valve integrated	●	●	●	●	<b>4</b>

**Filtration** (see page 31)

14	Without filter	●	●	●	●	<b>N</b>
	With threaded port for filter in the boost circuit	●	●	●	●	<b>D</b>
	With mounted filter (optical/electrical contamination indicator) in the boost circuit	●	●	●	●	<b>M</b>
	With threaded port for filter in the boost circuit (D) and intermediate plate filter for HS control (see data sheet 92076)	○	●	-	-	<b>Z</b>
	With mounted filter in the boost circuit (M) and intermediate plate filter for HS control (see data sheet 92076)	○	○	-	-	<b>U</b>

● = Available    ○ = On request    - = Not available

## Hydraulic fluids

The A4CSG variable pump is designed for operation with HLP mineral oil according to DIN 51524.

Application instructions and requirements for hydraulic fluids should be taken from the following data sheets prior to project planning:

- ▶ 90220: Hydraulic fluids based on mineral oils and related hydrocarbons
- ▶ 90221: Environmentally acceptable hydraulic fluids

### Notes on selection of hydraulic fluid

The hydraulic fluid should be selected so that the operating viscosity in the operating temperature range is within the optimum range ( $v_{opt}$ , see selection diagram).

#### Note

At no point on the component may the temperature be higher than 90 °C. The temperature difference specified in the table is to be taken into account when determining the viscosity in the bearing.

If the above conditions cannot be maintained due to extreme operating parameters, please contact the responsible member of staff at Bosch Rexroth.

### Viscosity and temperature of hydraulic fluids

	Viscosity	Temperature	Comment
Cold start	$v_{max} \leq 1000 \text{ mm}^2/\text{s}$	$\theta_{St} \geq -25 \text{ °C}$	$t \leq 3 \text{ min}$ , without load $p \leq 50 \text{ bar}$
Permissible temperature difference		$\Delta T \leq 25 \text{ K}$	between axial piston unit and hydraulic fluid in the system
Warm-up phase	$v = 1000 \text{ to } 100 \text{ mm}^2/\text{s}$	$\theta \geq -25 \text{ °C}$	at $p_{nom}$ , $0.5 \times n_{max}$ and $t \leq 15 \text{ min}$
Continuous operation	$v = 100 \text{ to } 16 \text{ mm}^2/\text{s}$	$\theta = -25 \text{ °C to } +90 \text{ °C}$	Note the permissible temperature range of the shaft seal measured at the drain port
	$v_{opt} = 36 \text{ to } 16 \text{ mm}^2/\text{s}$		Range of optimum operating viscosity and efficiency
Short-term operation	$v_{min} \leq 10 \text{ mm}^2/\text{s}$	$\theta_{max} = +90 \text{ °C}$	$t < 3 \text{ min}$ , $p < 0.3 \times p_{nom}$

#### ▼ Selection diagram

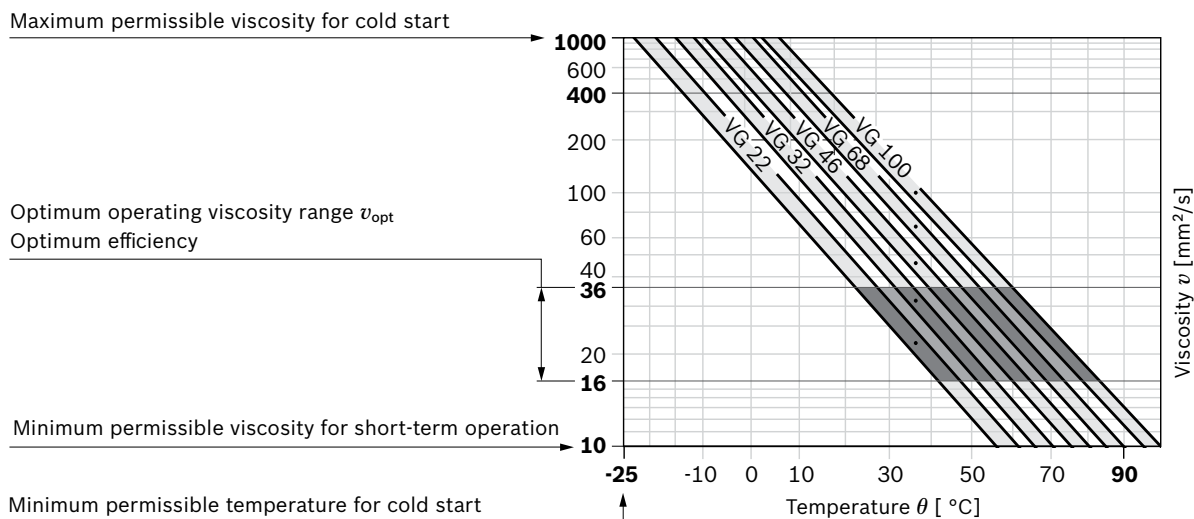

### Filtration of the hydraulic fluid

Finer filtration improves the cleanliness level of the hydraulic fluid, which increases the service life of the axial piston unit.

A cleanliness level of at least 20/18/15 is to be maintained according to ISO 4406.

Depending on the system and application, we recommend for the A4CSG filter cartridges  $\beta_{20} \geq 100$ .

A “threaded port for filter in the boost circuit” is optionally available with order designation **D** or “a filter mounted in the boost circuit” with order designation **M**. For a description, see pages 31 to 32.

### Bearing flushing

For the following operating conditions bearing flushing is required for a safe, continuous operation:

- ▶ Applications with special fluids (not mineral fluids) due to limited lubricity and narrow operating temperature range
- ▶ Operation with borderline conditions for temperature and viscosity during operation with mineral oil

With vertical installation (drive shaft upwards), bearing flushing is recommended for lubricating the front bearing and the shaft seal, otherwise a reduced service life of the shaft seal is to be expected.

Bearing flushing is realized at port “**U**” in the area of the front flange of the variable pump. The flushing fluid flows through the front bearing and discharges with the pump drain at the drain port.

Depending on the individual sizes, the following flushing flows are recommended:

Size		250	355	500	750
recommended flushing flow	$q_{sp}$ L/min	10	15	20	30

For the flushing flows stated, there is a pressure differential of approximately 3 bar between the port “**U**” (including fitting) and the housing area.

### Note on bearing flushing

When using bearing flushing on port **U**, the throttle screw in port **U** must be turned in to the end stop.

## Shaft seal

### Permissible pressure load

The service life of the shaft seal ring is affected by the rotational speed of the axial piston unit and the leakage pressure (case pressure). Momentary ( $t < 0.1$  s) pressure peaks of up to 10 bar are permitted. The service life of the shaft seal decreases with an increase in the frequency of pressure peaks and an increase in the mean differential pressure.

The pressure in the case must be equal to or greater than the ambient pressure.

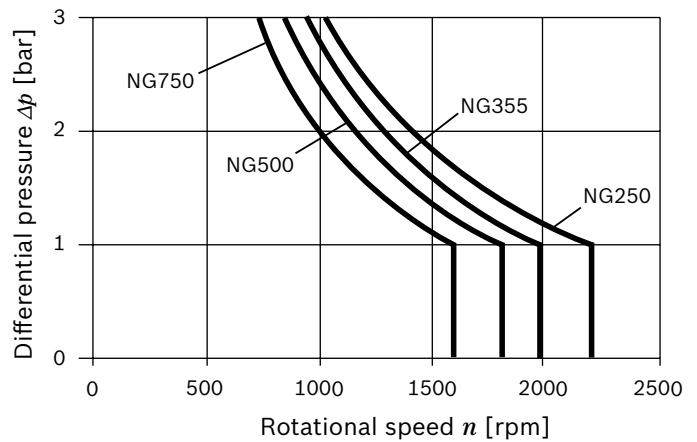

## Working pressure range

Pressure at working ports A or B		Definition
Nominal pressure $p_{nom}$	350 bar	The nominal pressure corresponds to the maximum design pressure.
Maximum pressure $p_{max}$	400 bar	The maximum pressure corresponds to the maximum working pressure within the single operating period. The sum of the single operating periods must not exceed the total operating period.
Single operating period	1 s	
Total operating period	300 h	
Minimum pressure (high-pressure side)	15 bar	Minimum pressure at the high-pressure side ( <b>A</b> or <b>B</b> ) which is required to prevent damage to the axial piston unit.
Minimum pressure (low-pressure side)	Speed related (see diagram)	Minimum pressure at the low-pressure side ( <b>A</b> or <b>B</b> ) which is required in order to prevent damage to the axial piston unit. The low pressure is present at port <b>M<sub>K4</sub></b> with the flushing slide deflected.
Rate of pressure change $R_{A\ max}$	16000 bar/s	Maximum permissible speed of pressure build-up and reduction during a pressure change across the entire pressure range.
Boost pressure		
Minimum boost pressure $p_{Sp}$ (at $n_{nom}$ )	16 bar	Measuring port <b>M<sub>K4</sub></b> (Please contact us for coupled multiple pumps)
	20 bar	
	10 bar	
Maximum static boost pressure $p_{Sp\ max}$	30 bar	
Permissible pressure peaks in boost pressure	minimum	4 bar
	maximum	40 bar
Pressure at suction port S (version with integrated boost pump)		
Minimum pressure $p_{S\ min}$	$\geq 0.8$ bar absolute	Minimum pressure at suction port <b>S</b> (inlet) that is required in order to avoid damage to the axial piston unit.
Maximum pressure $p_{S\ max}$	30 bar absolute	
Control pressure for EP and HD control.		
Minimum required control pressure $p_{St\ min}$	double boost pressure at NG 355 +5 bar	Measuring port <b>M1</b> (small stroking chamber)

### Required low pressure depending on the speed ratio

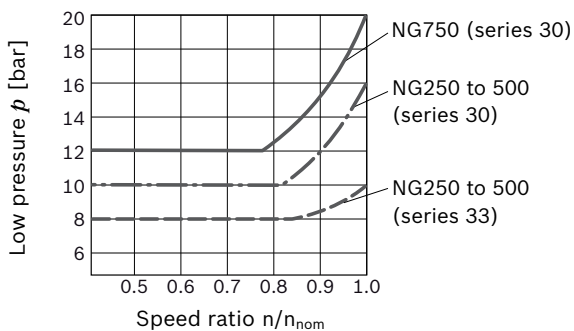

### Rate of pressure change

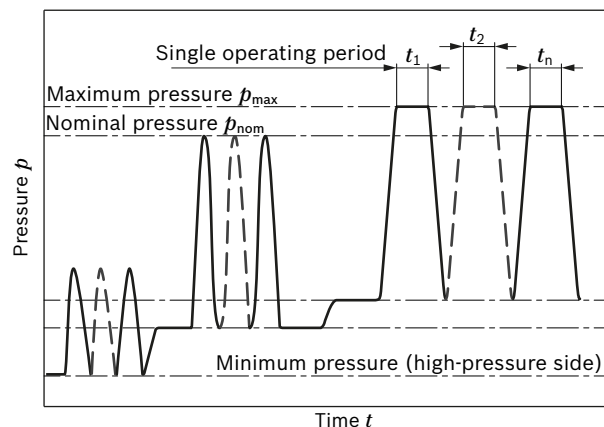
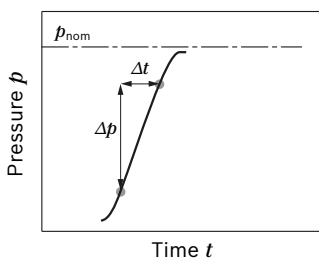

$$\text{Total operating period} = t_1 + t_2 + \dots + t_n$$

### Notice

Working pressure range valid when using hydraulic fluids based on mineral oils. Values for other hydraulic fluids, please contact us.

## Technical data

Size		NG		250	355	500	750
Displacement, geometric, per revolution	Variable pump	$V_{g \max}$	cm <sup>3</sup>	250	355	500	750
	Integrated boost pump	$V_{g \text{ Sp}}$	cm <sup>3</sup>	63	80	98	143
Rotational speed <sup>1)</sup>	maximum at $V_{g \max}$	$n_{\text{nom}}$	rpm	2200	2000	1800	1600
	minimal <sup>2)</sup>	$n_{\text{min}}$	rpm	800	800	800	800
Flow (variable pump) at $V_{g \max}$ and	$n_{\text{max}}$	$q_v$	L/min	550	710	900	1200
	$n_E = 1500$ rpm	$q_{vE}$	L/min	375	533	750	1125
Power <sup>3)</sup> at $V_{g \max}$ , $\Delta p = 350$ bar and	$n_{\text{max}}$	$P$	kW	321	414	525	700
	$n_E = 1500$ rpm	$P_E$	kW	219	311	438	656
Torque <sup>3)</sup> at $V_{g \max}$ and	$\Delta p = 350$ bar	$T$	Nm	1391	1976	2783	4174
	$\Delta p = 100$ bar	$T$	Nm	398	564	795	1193
Rotary stiffness of drive shaft	P	$c$	kNm/rad	527	800	1145	1860
	Z	$c$	kNm/rad	543	770	1209	1812
Moment of inertia for rotary group		$J_{\text{TW}}$	kgm <sup>2</sup>	0.0959	0.19	0.3325	0.66
Maximum angular acceleration <sup>4)</sup>		$\alpha$	rad/s <sup>2</sup>	775	600	540	400
Case volume		$V$	L	10	8	14	19
Weight (pump with EP control and integrated boost pump without filter) approx.		$m$	kg	260	275	390	520

### Determining the characteristics

$$\text{Flow} \quad q_v = \frac{V_g \cdot n \cdot \eta_v}{1000} \quad [\text{l/min}]$$

$$\text{Torque} \quad T = \frac{V_g \cdot \Delta p}{20 \cdot \pi \cdot \eta_{\text{mh}}} \quad [\text{Nm}]$$

$$\text{Power} \quad P = \frac{2 \pi \cdot T \cdot n}{60000} = \frac{q_v \cdot \Delta p}{600 \cdot \eta_t} \quad [\text{kW}]$$

#### Key

$V_g$  = Displacement per revolution [cm<sup>3</sup>]

$\Delta p$  = Differential pressure [bar]

$n$  = Rotational speed [rpm]

$\eta_v$  = Volumetric efficiency

$\eta_{\text{mh}}$  = Mechanical-hydraulic efficiency

$\eta_t$  = Total efficiency ( $\eta_t = \eta_v \cdot \eta_{\text{mh}}$ )

### Notice

- ▶ Theoretical values, without efficiency and tolerances; values rounded
- ▶ Operation above the maximum values or below the minimum values may result in a loss of function, a reduced service life or in the destruction of the axial piston unit. Bosch Rexroth recommends testing the loads by means of experiment or calculation / simulation and comparison with the permissible values.

### Flow direction

Direction of rotation	Swiveling range*	
clockwise	counter-clockwise	
B to A	A to B	clockwise
A to B	B to A	counter-clockwise

\* cf. swivel angle indicator

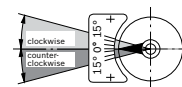

- The values are applicable:
  - for the optimum viscosity range from  $\nu_{\text{opt}} = 36$  to  $16 \text{ mm}^2/\text{s}$
  - for hydraulic fluid based on mineral oils
- Lower values on request
- Without boost pump
- The data are valid for values between the minimum required and maximum permissible rotational speed.  
Valid for external excitation (e.g. diesel engine 2 to 8 times rotary frequency, cardan shaft twice the rotary frequency).  
The limit value is only valid for a single pump.  
The load capacity of the connecting parts must be considered.

**Permissible radial and axial forces of the drive shafts**

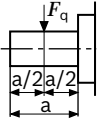
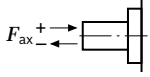
Size	NG	250	355	500	750	
Drive shaft						
Maximum radial force at X/2		$F_{q \max}$ N	2000	2200	2500	3000
Maximum axial force		$+ F_{ax \max}$ N $- F_{ax \max}$ N	1800	2000	2000	2000

**Note**

Special requirements apply in the case of belt drives.  
Please contact us.

**Permissible input and through-drive torques**

Size	NG	250	355	500	750
Torque at $V_{g \max}$ and $\Delta p = 350 \text{ bar}^1$	$T_{\max}$ Nm	1391	1976	2783	4174
Maximum input torque at drive shaft <sup>2)</sup>					
Splined shaft Z	$T_{E \max}$ Nm	2782	3952	5566	8348
Shaft key P	$T_{E \max}$ Nm	2300	3557	5200	7513
Maximum through-drive torque		$T_{D \max} = T_{E \max}$			

**Distribution of torques**

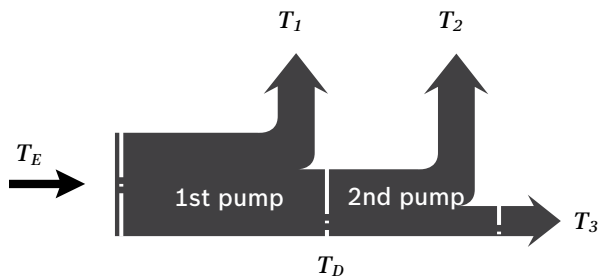

Torque at 1st pump	$T_1$
Torque at 2nd pump	$T_2$
Torque at 3rd pump	$T_3$
Input torque	$T_E = T_1 + T_2 + T_3$
	$T_E < T_{E \max}$
Through-drive torque	$T_D = T_2 + T_3$
	$T_D < T_{D \max}$

1) Efficiency not considered

2) For drive shafts free of radial force



## Overview of control devices

### HS5 – control system, hydraulic with proportional valve (see data sheet 92076)

The stepless displacement control is accomplished by means of a proportional valve and electrical feedback of the swivel angle.

The HS5P control system is equipped with mounted pressure transducers, which means that it can be used for electric pressure and power control.

Optional:

- ▶ With pressure transducer (HS5P)
- ▶ Short circuit valve (HS5K, HS5KP)
- ▶ For oil-immersed use (HS5M)

#### ▼ Characteristic curve

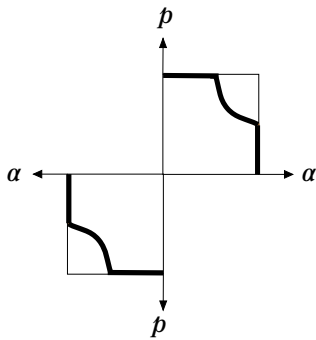

#### ▼ Circuit diagram

Example: A4CSG 250/355 HS5...F..4D

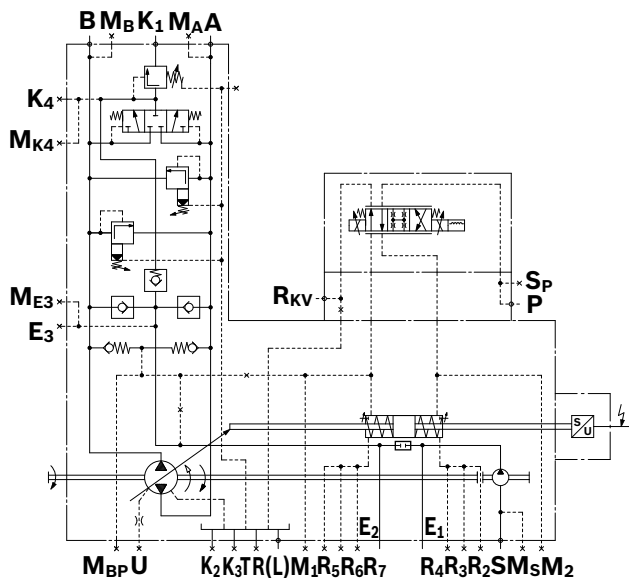

### EO2 – control system, hydraulic with proportional valve (see data sheet 92076)

The stepless control of the displacement flow is accomplished by means of a proportional valve and electrical feedback of the swivel angle.

Thus, the control can be used as an electric displacement control.

Optional:

- ▶ Short circuit valve (EO2K)

#### ▼ Characteristic curve

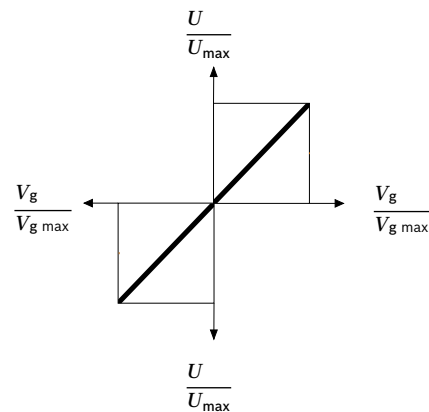

#### ▼ Circuit diagram

Example: A4CSG 500/750 EO2...F..4D

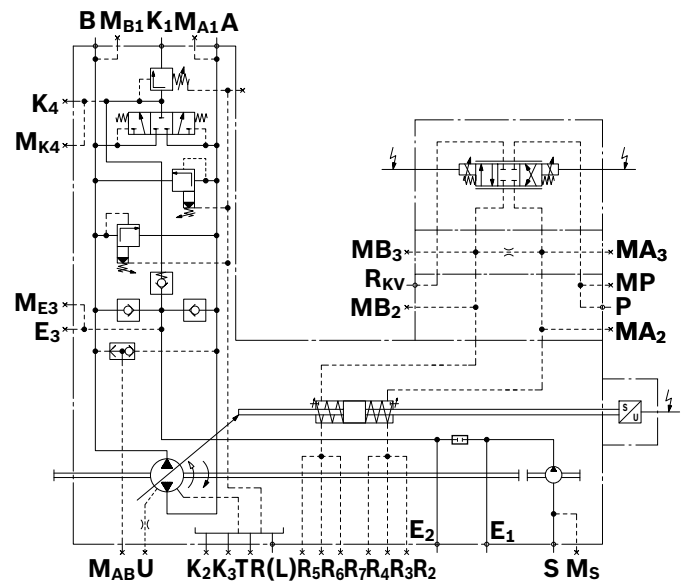

**HD – Proportional control, hydraulic, pilot-pressure related** (see data sheet 92080)

Stepless adjustment of the pump displacement according to the pilot pressure. The control is proportional to the specified pilot pressure setpoint value (difference between **X<sub>1</sub>**, **X<sub>2</sub>**).

For version **F** with integrated boost pump, the control is supplied internally with the control pressure from the boost circuit. This saves using a separate control pressure pump.

Optional:

- ▶ Control characteristics (HD1, HD2, HD3)
- ▶ Pressure control (HD.A, HD.B, HD.D)
- ▶ Remote pressure control (HD.GA, HD.GB, HD.G)
- ▶ Power control (HD1P)
- ▶ Electrical control of pilot pressure (HD1T)

▼ **Characteristic curve**

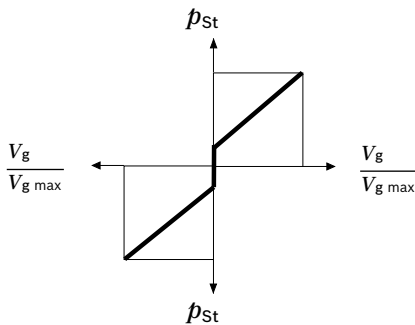

▼ **Circuit diagram**

Example: A4CSG 500/750 HD1...F.4M

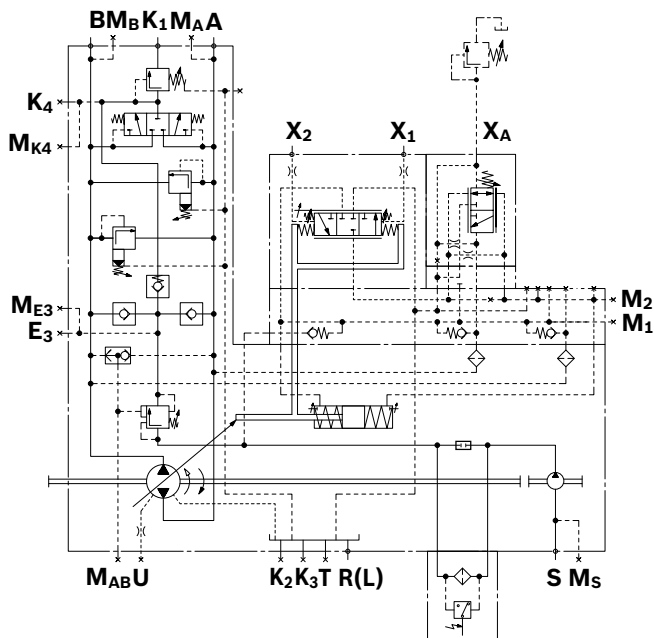

**EP – proportional control, electrohydraulic**

(see data sheet 92084)

The EP control adjusts the pump displacement proportionally to the current at the solenoid. Current-regulated control units with pulse-width modulation are recommended for controlling the solenoids.

For version **F** with integrated boost pump, the control is supplied internally with the control pressure from the boost circuit. This saves using a separate control pressure pump.

Optional:

- ▶ Pressure control (EPA, EPB, EPD)
- ▶ Remote pressure control (EPGA, EPGB, EPG)

▼ **Characteristic curve**

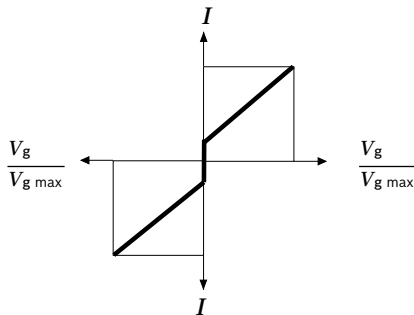

▼ **Circuit diagram**

Example: A4CSG 500/750 EPD...F..4D<sup>1)</sup>

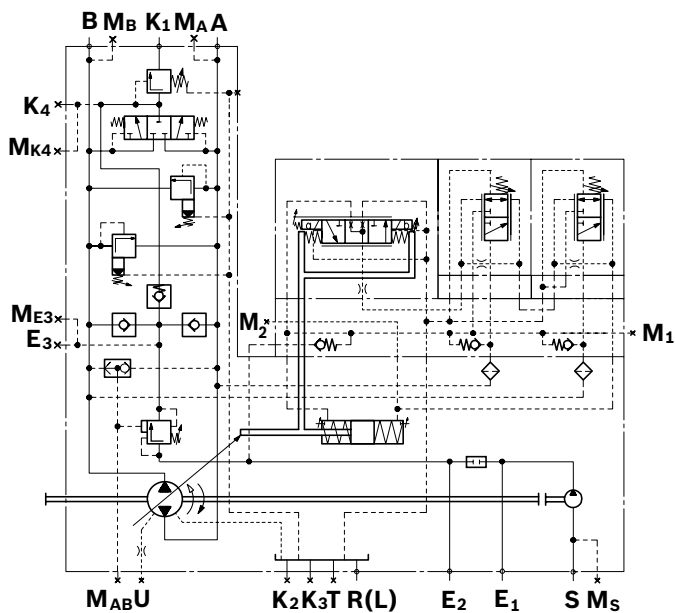

1) Version M with filter, see page 30



## ▼ Parallel keyed shaft DIN 6885

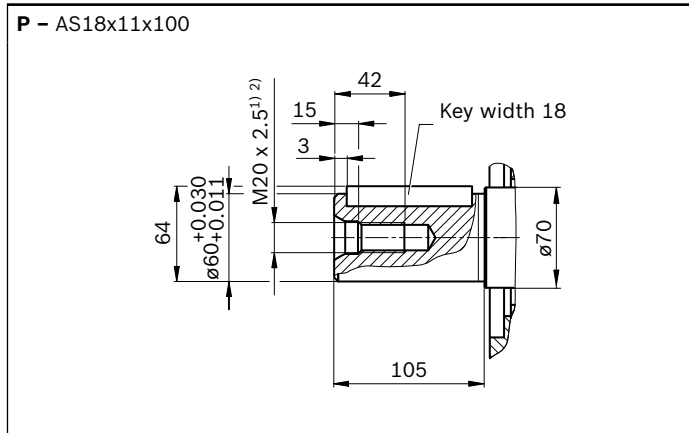

## ▼ Splined shaft DIN 5480

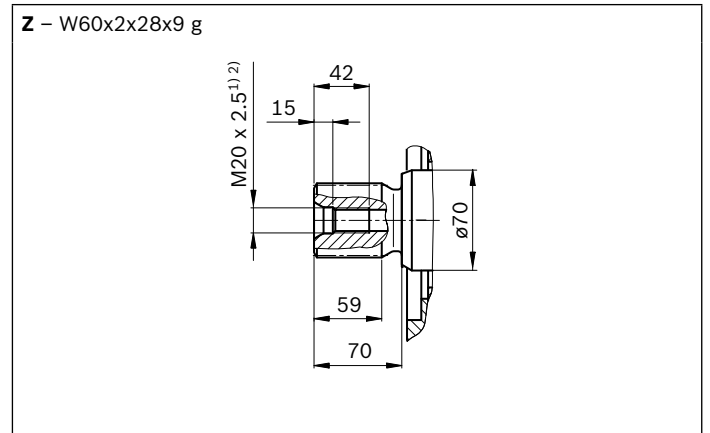

Ports	Standard	Size <sup>2)</sup>	$p_{max}$ [bar] <sup>3)</sup>	State <sup>7)</sup>	
<b>A, B</b>	Working line (high-pressure series)	SAE J518 <sup>4)</sup>	1 1/2 in	400	O
	Fastening thread A/B	DIN 13	M16 × 2; 21 deep		
<b>S</b>	Suction port (standard pressure series)	SAE J518 <sup>4)</sup>	2 1/2 in	30	O
	Fastening thread S	DIN 13	M12 × 1.75; 17 deep		
<b>M<sub>A</sub>, M<sub>B</sub>, M<sub>ABP</sub></b>	Measuring working pressure A/B	DIN 3852	M14 × 1.5; 12 deep	400	X
<b>M<sub>S</sub></b>	Measuring suction	DIN 3852	M14 × 1.5; 12 deep	30	X
<b>T</b>	Fluid drain	DIN 3852 <sup>5)</sup>	M42 × 2; 20 deep	4	X <sup>6)</sup>
<b>E<sub>1</sub></b>	Filter, supply	DIN 3852	M33 × 2; 18 deep	40	X
<b>E<sub>2</sub></b>	Filter, return	DIN 3852	M33 × 2; 18 deep	40	X
<b>K<sub>1</sub></b>	Flushing port	DIN 3852	M33 × 2; 18 deep	5	O
<b>K<sub>2</sub>, K<sub>3</sub></b>	Fluid filling + air bleeding	DIN 3852 <sup>5)</sup>	M42 × 2; 20 deep	4	X <sup>6)</sup>
<b>R(L)</b>	Return flow (drain port)			4	O <sup>6)</sup>
<b>U</b>	Bearing flushing	DIN 3852 <sup>5)</sup>	M14 × 1.5; 12 deep	7	X
<b>E<sub>3</sub></b>	Boost pressure supply	DIN 3852	M33 × 2; 18 deep	40	X
<b>M<sub>E3</sub></b>	Measuring boost pressure	DIN 3852	M14 × 1.5; 12 deep	40	X
<b>K<sub>4</sub></b>	Accumulator port	DIN 3852	M33 × 2; 18 deep	40	X
<b>M<sub>K4</sub></b>	Measuring boost pressure	DIN 3852	M14 × 1.5; 12 deep	40	X
<b>M<sub>1</sub>, M<sub>2</sub></b>	Measuring control pressure	DIN 3852	M18 × 1.5; 12 deep	400	X
<b>X<sub>A</sub>, X<sub>B</sub></b>	Pilot pressure, remote control pressure controller	DIN 3852	M14 × 1.5; 12 deep	350	O

- Center bore according to DIN 332 (thread according to DIN 13)
- For notes on tightening torques, see the instruction manual
- Depending on the application, momentary pressure peaks can occur. Keep this in mind when selecting measuring devices and fittings.
- Only dimensions according to SAE J518, metric fastening thread is a deviation from standard.

- The countersink can be deeper than that specified in the standard.
- Depending on the installation position, T, K<sub>2</sub>, K<sub>3</sub> or R(L) must be connected (see also pages 33 to 35)
- O = Must be connected (plugged when delivered)  
X = Plugged (in normal operation)

**Dimensions, size 355**

A4CSG355EPG/30R-XXB35F994N

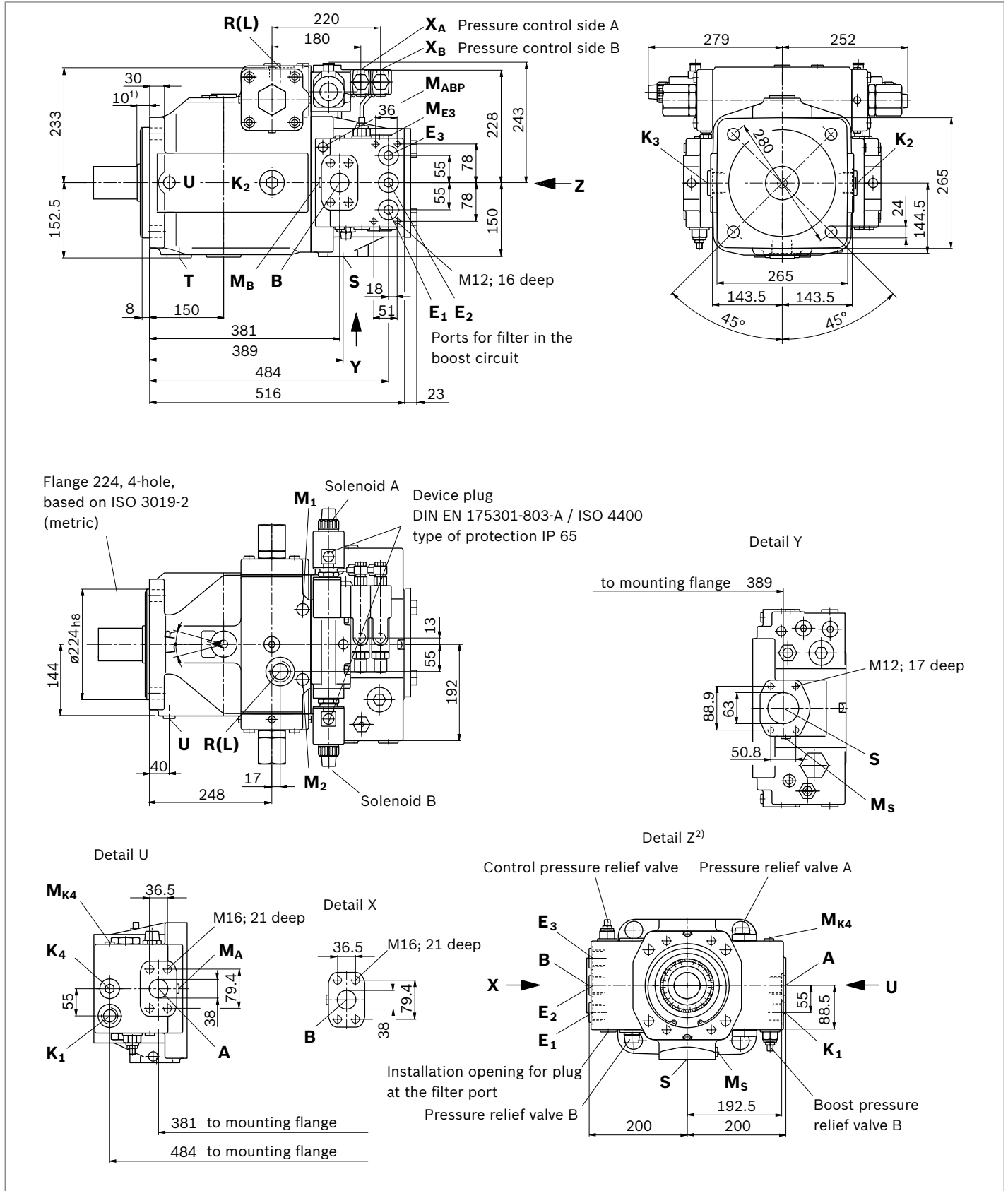

1) Up to shaft collar

2) Through drive F99 shown without cover, for dimensions see page 22

## ▼ Parallel keyed shaft DIN 6885

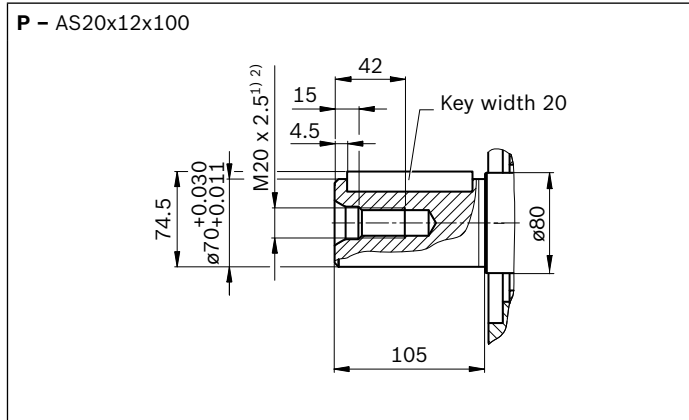

## ▼ Splined shaft DIN 5480

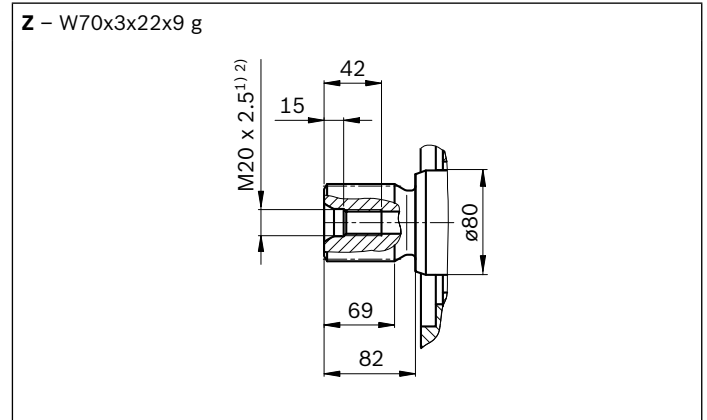

Ports	Standard	Size <sup>2)</sup>	$p_{\max}$ [bar] <sup>3)</sup>	State <sup>7)</sup>	
<b>A, B</b>	Working line (high-pressure series)	SAE J518 <sup>4)</sup>	1 1/2 in	400	O
	Fastening thread A/B	DIN 13	M16 × 2; 21 deep		
<b>S</b>	Suction port (standard pressure series)	SAE J518 <sup>4)</sup>	2 1/2 in	30	O
	Fastening thread S	DIN 13	M12 × 1.75; 17 deep		
<b>M<sub>A</sub>, M<sub>B</sub>, M<sub>ABP</sub></b>	Measuring working pressure A/B	DIN 3852	M14 × 1.5; 12 deep	400	X
<b>M<sub>S</sub></b>	Measuring suction	DIN 3852	M14 × 1.5; 12 deep	30	X
<b>T</b>	Fluid drain	DIN 3852 <sup>5)</sup>	M42 × 2; 20 deep	4	X <sup>6)</sup>
<b>E<sub>1</sub></b>	Filter, supply	DIN 3852	M33 × 2; 18 deep	40	X
<b>E<sub>2</sub></b>	Filter, return	DIN 3852	M33 × 2; 18 deep	40	X
<b>K<sub>1</sub></b>	Flushing port	DIN 3852	M33 × 2; 18 deep	5	O
<b>K<sub>2</sub>, K<sub>3</sub></b>	Fluid filling + air bleeding	DIN 3852 <sup>5)</sup>	M42 × 2; 20 deep	4	X <sup>6)</sup>
<b>R(L)</b>	Return flow (drain port)			4	O <sup>6)</sup>
<b>U</b>	Bearing flushing	DIN 3852 <sup>5)</sup>	M18 × 1.5; 12 deep	7	X
<b>E<sub>3</sub></b>	Boost pressure supply	DIN 3852	M33 × 2; 18 deep	40	X
<b>M<sub>E3</sub></b>	Measuring boost pressure	DIN 3852	M14 × 1.5; 12 deep	40	X
<b>K<sub>4</sub></b>	Accumulator port	DIN 3852	M33 × 2; 18 deep	40	X
<b>M<sub>K4</sub></b>	Measuring boost pressure	DIN 3852	M14 × 1.5; 12 deep	40	X
<b>M<sub>1</sub>, M<sub>2</sub></b>	Measuring control pressure	DIN 3852	M18 × 1.5; 12 deep	400	X
<b>X<sub>A</sub>, X<sub>B</sub></b>	Pilot pressure, remote control pressure controller	DIN 3852	M14 × 1.5; 12 deep	350	O

1) Center bore according to DIN 332 (thread according to DIN 13)

2) For notes on tightening torques, see the instruction manual

3) Depending on the application, momentary pressure peaks can occur. Keep this in mind when selecting measuring devices and fittings.

4) Only dimensions according to SAE J518, metric fastening thread is a deviation from standard.

5) The countersink can be deeper than that specified in the standard.

6) Depending on the installation position, T, K<sub>2</sub>, K<sub>3</sub> or R(L) must be connected (see also pages 33 to 35)

7) O = Must be connected (plugged when delivered)

X = Plugged (in normal operation)

**Dimensions, size 500**

A4CSG500EPD/30R-XXH35F994N

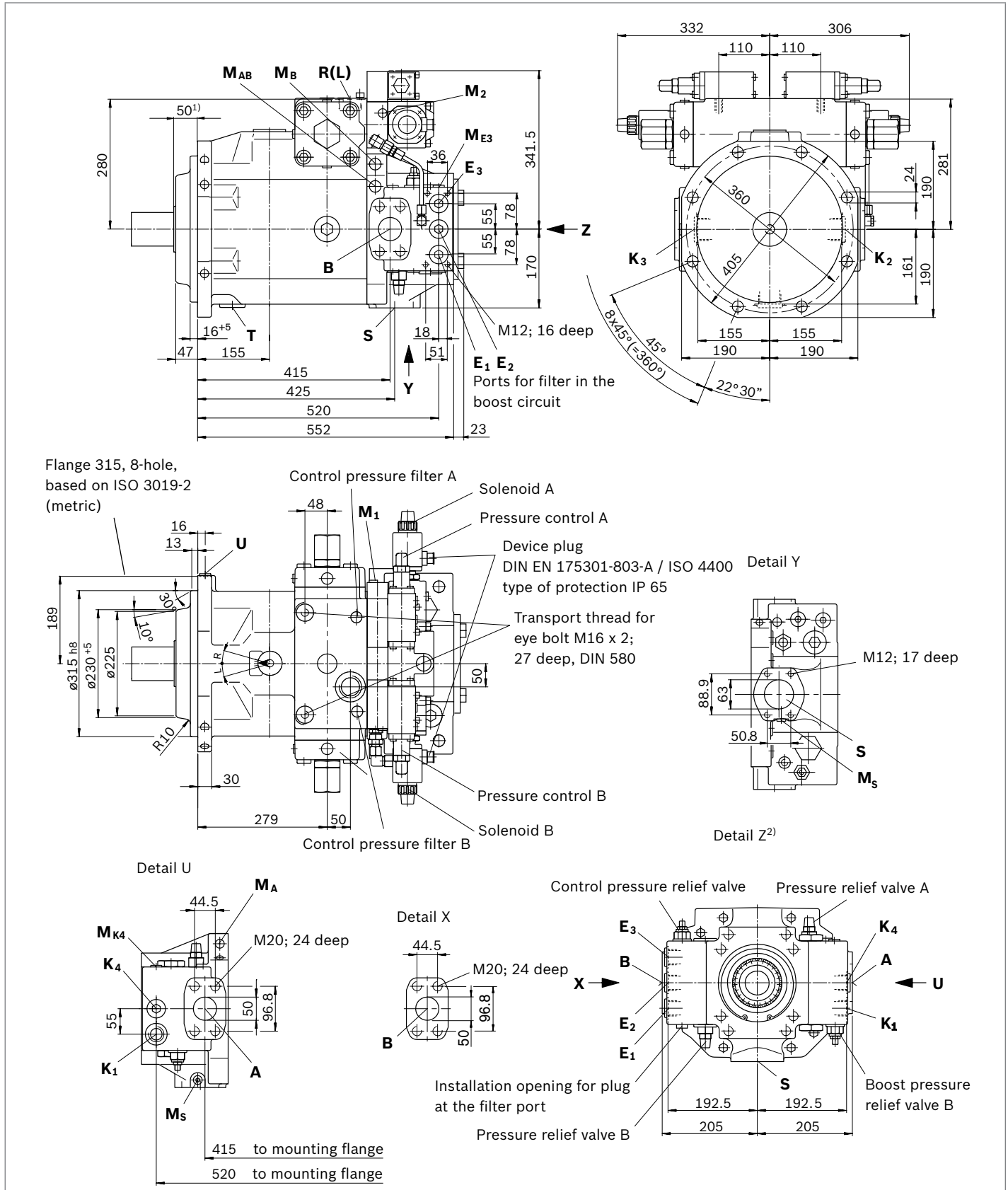



## ▼ Parallel keyed shaft DIN 6885

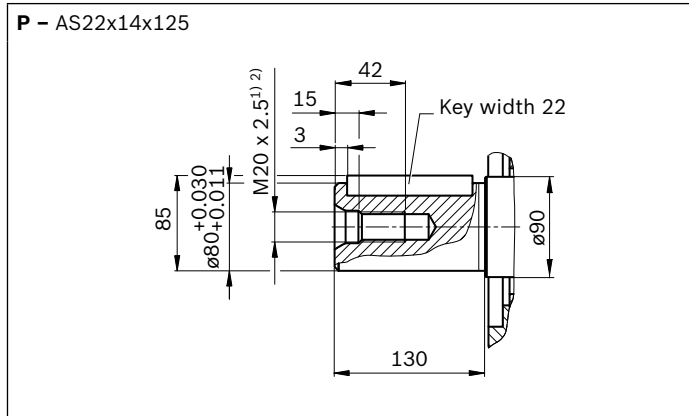

## ▼ Splined shaft DIN 5480

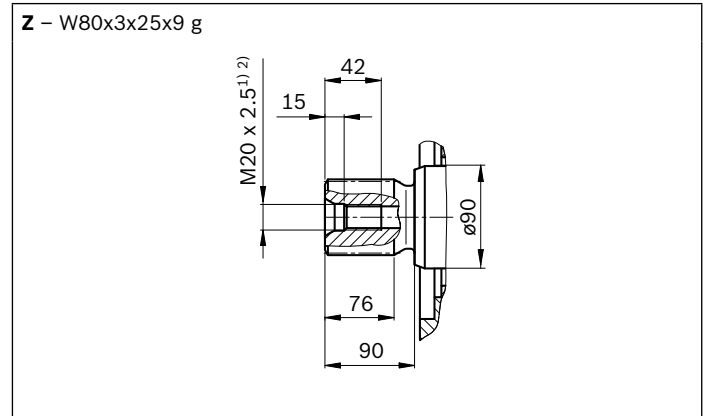

Ports	Standard	Size <sup>2)</sup>	$p_{max}$ [bar] <sup>3)</sup>	State <sup>7)</sup>	
<b>A, B</b>	Working line (high-pressure series)	SAE J518 <sup>4)</sup>	2 in	400	O
	Fastening thread A/B	DIN 13	M20 × 2.5; 24 deep		
<b>S</b>	Suction port (standard pressure series)	SAE J518 <sup>4)</sup>	2 1/2 in	30	O
	Fastening thread S	DIN 13	M12 × 1.75; 17 deep		
<b>M<sub>A</sub>, M<sub>B</sub>, M<sub>ABP</sub></b>	Measuring working pressure A/B	DIN 3852	M14 × 1.5; 12 deep	400	X
<b>M<sub>S</sub></b>	Measuring suction	DIN 3852	M14 × 1.5; 12 deep	30	X
<b>T</b>	Fluid drain	DIN 3852 <sup>5)</sup>	M48 × 2; 22 deep	4	X <sup>6)</sup>
<b>E<sub>1</sub></b>	Filter, supply	DIN 3852	M33 × 2; 18 deep	40	X
<b>E<sub>2</sub></b>	Filter, return	DIN 3852	M33 × 2; 18 deep	40	X
<b>K<sub>1</sub></b>	Flushing port	DIN 3852	M33 × 2; 18 deep	5	O
<b>K<sub>2</sub>, K<sub>3</sub></b>	Fluid filling + air bleeding	DIN 3852 <sup>5)</sup>	M48 × 2; 22 deep	4	X <sup>6)</sup>
<b>R(L)</b>	Return flow (drain port)			4	O <sup>6)</sup>
<b>U</b>	Bearing flushing	DIN 3852 <sup>5)</sup>	M18 × 1.5; 12 deep	7	X
<b>E<sub>3</sub></b>	Boost pressure supply	DIN 3852	M33 × 2; 18 deep	40	X
<b>M<sub>E3</sub></b>	Measuring boost pressure	DIN 3852	M14 × 1.5; 12 deep	40	X
<b>K<sub>4</sub></b>	Accumulator port	DIN 3852	M33 × 2; 18 deep	40	X
<b>M<sub>K4</sub></b>	Measuring boost pressure	DIN 3852	M14 × 1.5; 12 deep	40	X
<b>M<sub>1</sub></b>	Measuring stroking chamber pressure	DIN 3852	M22 × 1.5; 14 deep	400	X
<b>M<sub>2</sub></b>	Measuring stroking chamber pressure	DIN 3852	M14 × 1.5; 12 deep	400	X
<b>X<sub>A</sub>, X<sub>B</sub></b>	Pilot pressure, remote control pressure controller	DIN 3852	M14 × 1.5; 12 deep	350	O

- Center bore according to DIN 332 (thread according to DIN 13)
- For notes on tightening torques, see the instruction manual
- Depending on the application, momentary pressure peaks can occur. Keep this in mind when selecting measuring devices and fittings.
- Only dimensions according to SAE J518, metric fastening thread is a deviation from standard.

- The countersink can be deeper than that specified in the standard.
- Depending on the installation position, T, K<sub>2</sub>, K<sub>3</sub> or R(L) must be connected (see also pages 33 to 35)
- O = Must be connected (plugged when delivered)  
X = Plugged (in normal operation)



## ▼ Parallel keyed shaft DIN 6885

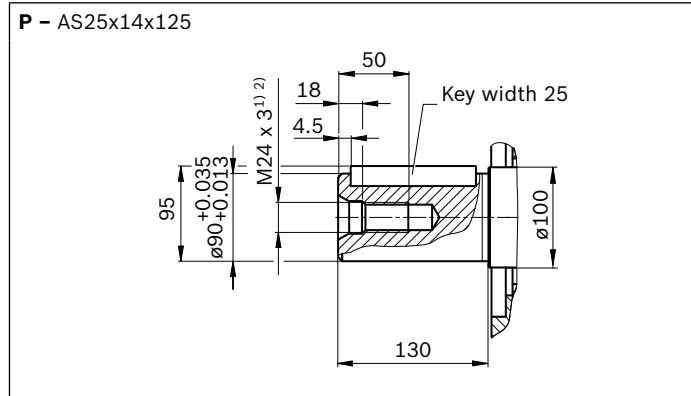

## ▼ Splined shaft DIN 5480

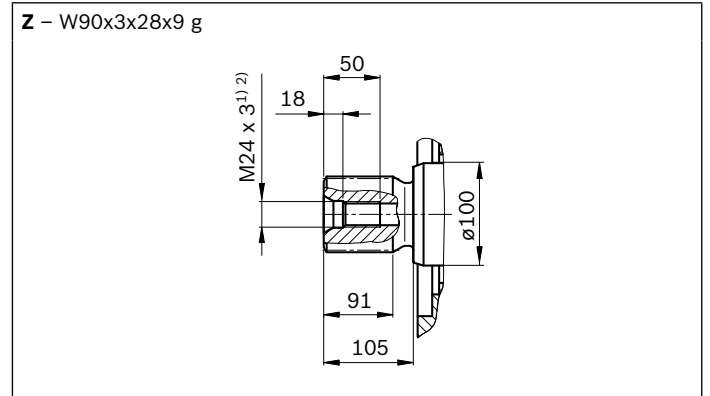

Ports	Standard	Size <sup>2)</sup>	$p_{\max}$ [bar] <sup>3)</sup>	State <sup>7)</sup>	
<b>A, B</b>	Working line (high-pressure series)	SAE J518 <sup>4)</sup>	2 in	400	O
	Fastening thread A/B	DIN 13	M20 × 2.5; 24 deep		
<b>S</b>	Suction port (standard pressure series)	SAE J518 <sup>4)</sup>	2 1/2 in	30	O
	Fastening thread S	DIN 13	M12 × 1.75; 17 deep		
<b>M<sub>A</sub>, M<sub>B</sub>, M<sub>ABP</sub></b>	Measuring working pressure A/B	DIN 3852	M14 × 1.5; 12 deep	400	X
<b>M<sub>S</sub></b>	Measuring suction	DIN 3852	M14 × 1.5; 12 deep	30	X
<b>T</b>	Fluid drain	DIN 3852 <sup>5)</sup>	M48 × 2; 22 deep	4	X <sup>6)</sup>
<b>E<sub>1</sub></b>	Filter, supply	DIN 3852	M33 × 2; 18 deep	40	X
<b>E<sub>2</sub></b>	Filter, return	DIN 3852	M33 × 2; 18 deep	40	X
<b>K<sub>1</sub></b>	Flushing port	DIN 3852	M33 × 2; 18 deep	5	O
<b>K<sub>2</sub>, K<sub>3</sub></b>	Fluid filling + air bleeding	DIN 3852 <sup>5)</sup>	M48 × 2; 22 deep	4	X <sup>6)</sup>
<b>R(L)</b>	Return flow (drain port)			4	O <sup>6)</sup>
<b>U</b>	Bearing flushing	DIN 3852 <sup>5)</sup>	M18 × 1.5; 12 deep	7	X
<b>E<sub>3</sub></b>	Boost pressure supply	DIN 3852	M33 × 2; 18 deep	40	X
<b>M<sub>E3</sub></b>	Measuring boost pressure	DIN 3852	M14 × 1.5; 12 deep	40	X
<b>K<sub>4</sub></b>	Accumulator port	DIN 3852	M33 × 2; 18 deep	40	X
<b>M<sub>K4</sub></b>	Measuring boost pressure	DIN 3852	M14 × 1.5; 12 deep	40	X
<b>M<sub>1</sub></b>	Measuring stroking chamber pressure	DIN 3852	M22 × 1.5; 14 deep	400	X
<b>M<sub>2</sub></b>	Measuring stroking chamber pressure	DIN 3852	M14 × 1.5; 12 deep	400	X
<b>X<sub>A</sub>, X<sub>B</sub></b>	Pilot pressure, remote control pressure controller	DIN 3852	M14 × 1.5; 12 deep	350	O

- Center bore according to DIN 332 (thread according to DIN 13)
- For notes on tightening torques, see the instruction manual
- Depending on the application, momentary pressure peaks can occur. Keep this in mind when selecting measuring devices and fittings.
- Only dimensions according to SAE J518, metric fastening thread is a deviation from standard.

- The countersink can be deeper than that specified in the standard.
- Depending on the installation position, T, K<sub>2</sub>, K<sub>3</sub> or R(L) must be connected (see also pages 33 to 35)
- O = Must be connected (plugged when delivered)  
X = Plugged (in normal operation)

## Through drive

The variable pump A4CSG can be supplied with through drive despite the integrated boost pump, in accordance with the type code on page 3.

If no further pumps are to be mounted at the factory, then the simple type designation is sufficient.

### The scope of delivery then includes

- ▶ for all through drives except F/K99:
  - hub, mounting bolts, seal and, if applicable, an intermediate flange
- ▶ for F/K99:
  - with through-drive shaft, without hub, without intermediate flange; unit with closed fluid-tight, pressure-tight cover

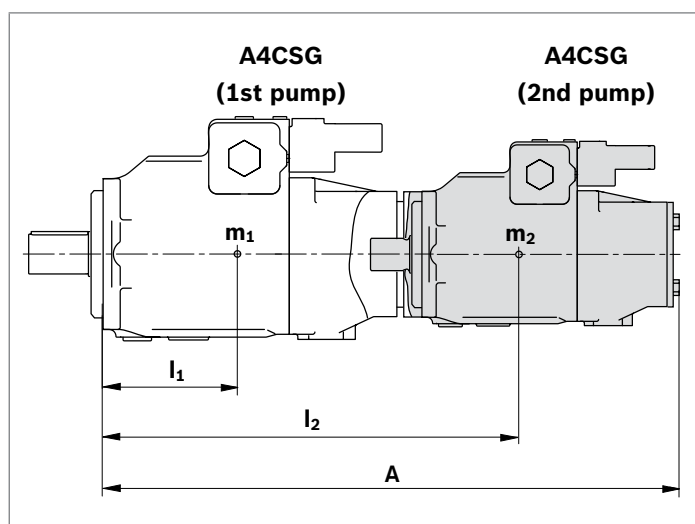

## Combination pumps

By using combination pumps, it is possible to have independent circuits without the need for splitter gearboxes.

When ordering combination pumps, the type designations of the 1st and 2nd pump must be connected by a “+”.

### ▶ Order example:

**A4CSG 500 EPG / 30 R – VPH35F434M +  
A4CSG 500 EPG / 30 R – VZH35F994M**

For through drives **F/K01, 04, 07, 24, 52, 68** and **B6**, various possible attachment angle positions are available. As standard, the second pump is attached at the same angle as the supplied screws, as shown in the drawing on pages 26 and 27. If this angle differs, please contact us.

If a gear pump is to be mounted at the factory as an attachment pump, please contact us.

For maximum permissible drive and through-drive torques, see page 8.

$m_1, m_2$  [kg]

$l_1, l_2$  [mm]

$$T_m = (m_1 \cdot l_1 + m_2 \cdot l_2 + m_3 \cdot l_3) \frac{1}{102} \text{ [Nm]}$$

### Total length A

A4CSG (1st pump)	A4CSG (2nd pump with through drive F/k99, without filter)			
	NG250	NG355	NG500	NG750
NG250	1079	–	–	–
NG355	1086	1114	–	–
NG500	1143	1150	1235	–
NG750	1210	1217	1302	1396

### Permissible mass torque

Size			250	355	500	750
Permissible mass torque	$T_m$	Nm	9300	9300	15600	19500
Permissible mass torque for dynamic mass acceleration $10g \approx 98.1 \text{ m/s}^2$	$T_m$	Nm	930	930	1560	1950
Weight	$m_1$	kg	260	275	390	520
Distance from center of gravity	$l_1$	mm	270	280	300	330

**Overview of mounting options on A4CSG**

Through drive - A4CSG			Mounting option 2nd pump				
Flange	Hub for splined shaft <sup>1)</sup>	Code	A4CSG NG (shaft)	A4VSO/G NG (shaft)	A10V(S)O/31/32 <sup>4)</sup> NG (shaft)	A10V(S)O/52/53 NG (shaft)	External/internal gear pump
<b>Flange ISO 3019-2 (metric)</b>							
80, 2-hole	3/4 in (19-4)	<b>F/KB2</b>	–	–	18 (S)/31	10 (S)	–
100, 2-hole	7/8 in (22-4)	<b>F/KB3</b>	–	–	28 (S)/31	–	–
	1 in (25-4)	<b>F/KB4</b>	–	–	45 (S)/31	–	–
125, 2-hole	1 1/4 in (32-4)	<b>F/KB5</b>	–	–	71 (S)/31	–	–
	1 1/2 in (38-4)	<b>F/KB6</b>	–	–	100 (S)/31	–	–
125, 4-hole	W32	<b>F/K31</b>	–	40 (Z)	–	–	–
125, 4-hole	1 in (25-4)	<b>F/KE1</b>	–	–	45 (S)/32	–	–
140, 4-hole	W40	<b>F/K33</b>	–	71 (Z)	–	–	–
160, 4-hole	W50	<b>F/K34</b>	–	125, 180 (Z)	–	–	–
	1 1/4 in (32-4)	<b>F/KB8</b>	–	–	71 (S)/32	–	–
180, 4-hole	1 1/2 in (38-4)	<b>F/KB9</b>	–	–	100 (S)/32	–	–
	1 3/4 in (44-4)	<b>F/KB7</b>	–	–	140 (S)/31/32	–	–
224, 4-hole	W60	<b>F/K35</b>	250 (Z)	250 (Z)	–	–	–
	W70	<b>F/K77</b>	355 (Z)	355 (Z)	–	–	–
315, 8-hole	W80	<b>F/K43</b>	500 (Z)	500 (Z)	–	–	–
400, 8-hole	W90	<b>F/K76</b>	750 (Z)	750 (Z)	–	–	–
<b>Flange SAE J744 (ISO 3019-1)<sup>2)</sup></b>							
82-2 (A)	5/8 in (16-4)	<b>F/K01</b>	–	–	–	–	AZPF-1X-004 to 022 <sup>3)</sup>
	3/4 in (19-4)	<b>F/K52</b>	–	–	18 (S)/31	10 (S)	–
101-2 (B)	7/8 in (22-4)	<b>F/K68</b>	–	–	28 (S)/31	28 (S)	AZPN-1X-020 to 032 <sup>3)</sup>
	1 in (25-4)	<b>F/K04</b>	–	–	45 (S)/31	45 (S)	PGH4
127-2 (C)	1 1/4 in (32-4)	<b>F/K07</b>	–	–	71 (S)/31	–	–
	1 1/2 in (38-4)	<b>F/K24</b>	–	–	100 (S)/31	85 (S)	PGH5
127-4 (C)	1 1/4 in (32-4)	<b>F/KE15</b>	–	–	71 (S)/32	–	–
152-4 (D)	1 3/4 in (44-4)	<b>F/K17</b>	–	–	140 (S)/31	–	–

1) According to DIN 5480 (e.g. W32) or according to SAE J744 (e.g. 3/4 in)

2) 2 = 2-hole, 4 = 4-hole

3) Bosch Rexroth recommends special versions of the gear pumps. Please contact us.

4) If a through drive for an A10V(S)O with R-shaft is desired, please contact us.

### Dimensions through drive

with through-drive shaft without hub or intermediate flange, plugged with fluid-tight, pressure-tight cover and O-ring for later mounting	Splined shaft DIN 5480	Availability over sizes				Code
	Diameter	250	355	500	750	F/K
	W42x1.25x32x9 g	●	●	-	-	99
	W55x1.25x42x9 g	-	-	●	●	99

● = Available    - = Not available

#### ▼ F/K99

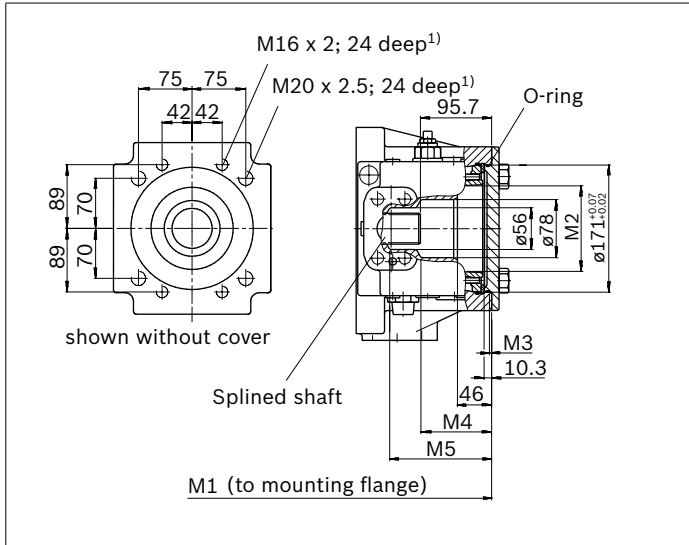

99	NG	M1	M2	M3	M4	M5
	250	509	∅115	3	95	137
	355	516	∅115	3	95	137

#### ▼ F/K99

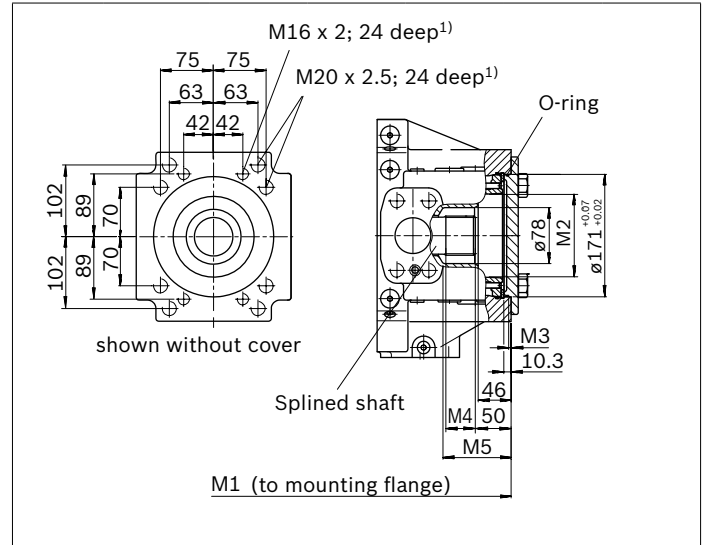

99	NG	M1	M2	M3	M4	M5
	500	552	∅115	3.4	41	95
	750	619	∅115	3.4	45	116.6

1) Thread according to DIN 13, see instruction manual for details on tightening torques

Flange ISO 3019-2		Availability over sizes				Code
Diameter	Hub for splined shaft DIN 5480	250	355	500	750	F/K
125, 4-hole	W32x2x14x9 g	○	●	●	○	<b>31</b>
140, 4-hole	W40x2x18x9 g	○	○	●	○	<b>33</b>
160, 4-hole	W50x2x24x9 g	●	●	●	●	<b>34</b>
224, 4-hole	W60x2x28x9 g	●	○	○	○	<b>35</b>

● = Available    ○ = On request

▼ F/K31

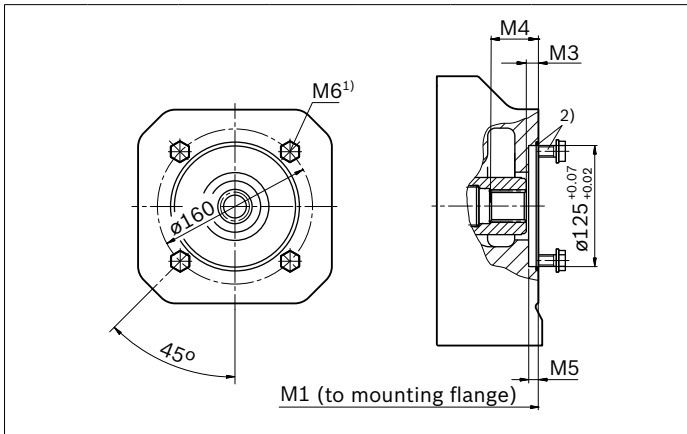

31	NG	M1	M3	M4	M5	M6
<b>355</b>	539	11.5	46	10	M12; 18 deep	
<b>500</b>	575	12.5	51	10		

▼ F/K33

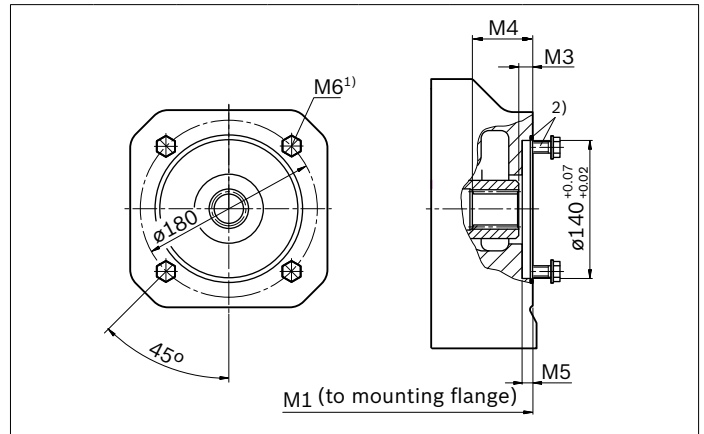

33	NG	M1	M3	M4	M5	M6
<b>355</b>	541	12.5	60	10	M12; 14.5 deep	
<b>500</b>	577	14.5	50	10		

▼ F/K34

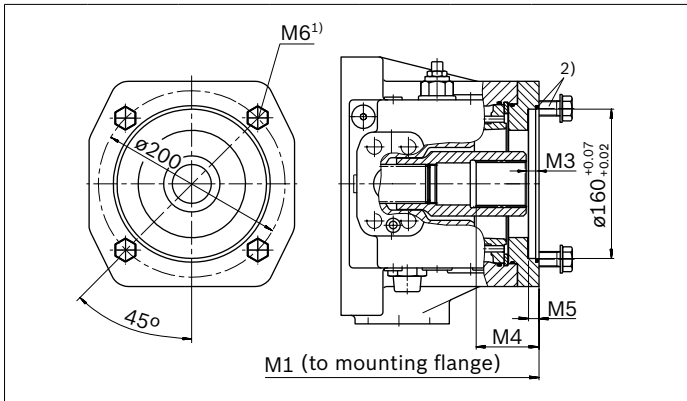

34	NG	M1	M3	M4	M5	M6
<b>250</b>	531	12.5	66	10	M16; 22 deep	
<b>355</b>	538	12.5	66	10		
<b>500</b>	574	12.5	67	10		
<b>750</b>	641	12.5	67	10		

▼ F/K35

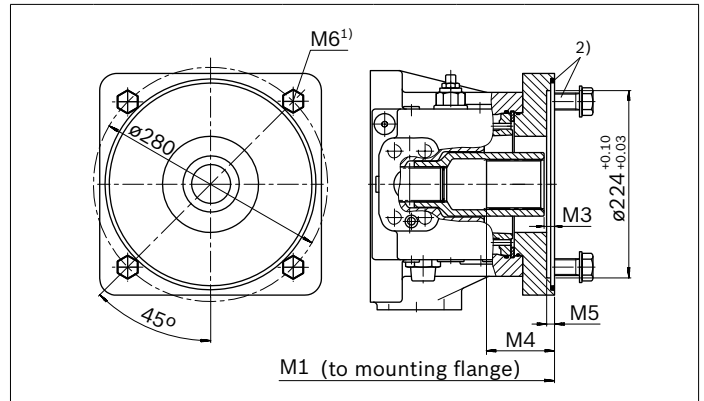

35	NG	M1	M3	M4	M5	M6
<b>250</b>	547	12.5	81	8	M20; 30 deep	
<b>355</b>	554	12.5	81	8		
<b>500</b>	611	12.5	81	8		
<b>750</b>	678	12.5	81	8		

1) Thread according to DIN 13, see instruction manual for details on tightening torques

2) 4 mounting bolts and O-ring seal are included in the scope of delivery.

Flange ISO 3019-2 Diameter	Hub for splined shaft DIN 5480	Availability over sizes				Code
		250	355	500	750	F/K
224, 4-hole	W70x3x22x9 g	○	●	●	○	<b>77</b>
315, 8-hole	W80x3x25x9 g	○	○	●	○	<b>43</b>

● = Available    ○ = On request

▼ F/K77

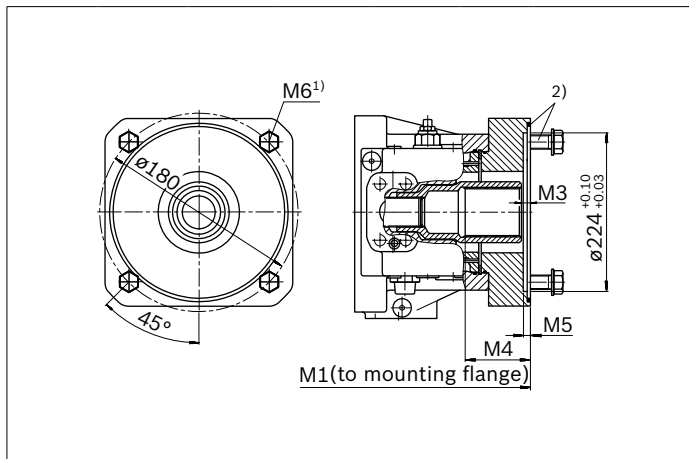

77	NG	M1	M3	M4	M5	M6
355	575	12.4	92	8	M20; 30 deep	
500	611	12.5	94.5	8		

▼ F/K43

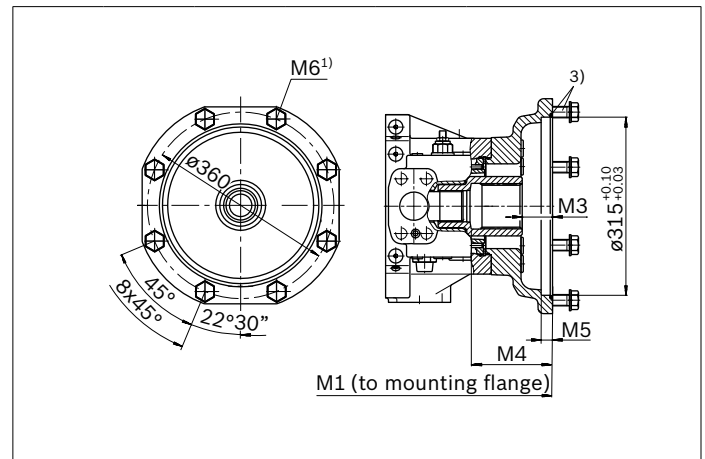

43	NG	M1	M3	M4	M5	M6
500	660	53.5	143	19	M20; 26 deep	

1) Thread according to DIN 13, see instruction manual for details on tightening torques  
2) 4 mounting bolts and O-ring seal are included in the scope of delivery.

3) 8 mounting bolts and O-ring seal are included in the scope of delivery.



Flange ISO 3019-2 Diameter	Hub for splined shaft SAE J744	Availability over sizes				Code F/K
		250	355	500	750	
100, 2-hole	7/8 in 13T 16/32DP	●	●	○	○	<b>B3</b>
125, 2-hole	1 1/4 in 14T 12/24DP	●	○	○	○	<b>B5</b>
125, 2-hole	1 1/2 in 17T 12/24DP	○	●	○	○	<b>B6</b>

● = Available    ○ = On request

▼ **F/KB3**

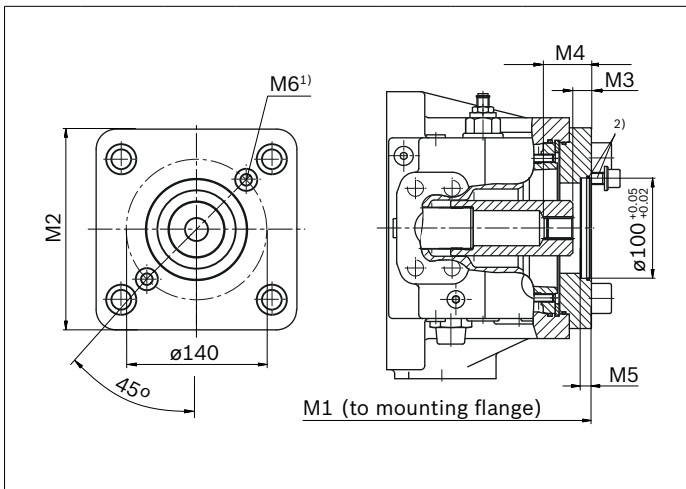

B3	NG	M1	M2	M3	M4	M5	M6
<b>250</b>	531	200	18.5	43.5	10	M12; 18 deep	
<b>355</b>	538	200	18.5	43.5	10		

▼ **F/KB5**

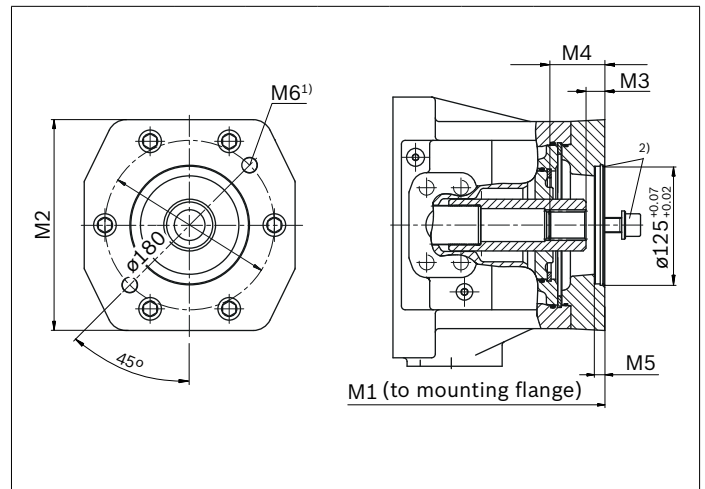

B5	NG	M1	M2	M3	M4	M5	M6
<b>250</b>	545	224	19.9	58	10	M16; 24 deep	
<b>355</b>	552	224	19.9	58	10		

▼ **F/KB6**

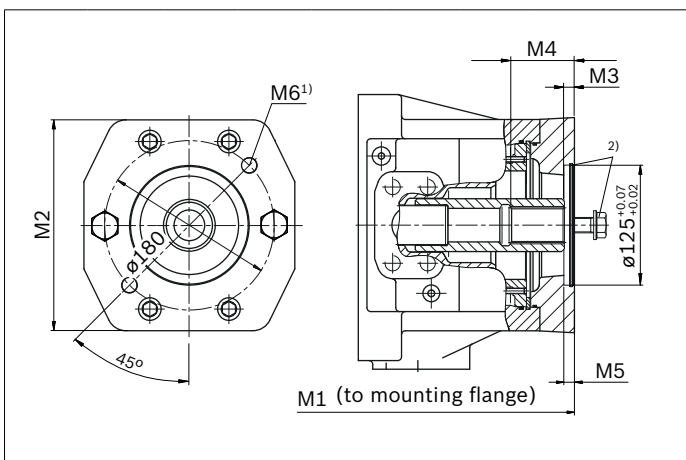

B6	NG	M1	M2	M3	M4	M5	M6
<b>355</b>	552	224	10	66	10.4	M16; 24 deep	

1) Thread according to DIN 13, see instruction manual for details on tightening torques

2) 2 mounting bolts and O-ring seal are included in the scope of delivery.

Flange SAE J744 (ISO 3019-1) Diameter	Hub for splined shaft SAE J744	Availability over sizes				Code
		250	355	500	750	F/K
82-2 (A)	5/8 in 9T 16/32DP	●	●	●	●	<b>01</b>
82-2 (A)	3/4 in 11T 16/32DP	○	●	●	○	<b>52</b>
101-2 (B)	7/8 in 13T 16/32DP	●	●	●	○	<b>68</b>
101-2 (B)	1 in 15T 16/32DP	○	●	●	○	<b>04</b>

● = Available    ○ = On request

▼ **F/K01; F/K52**

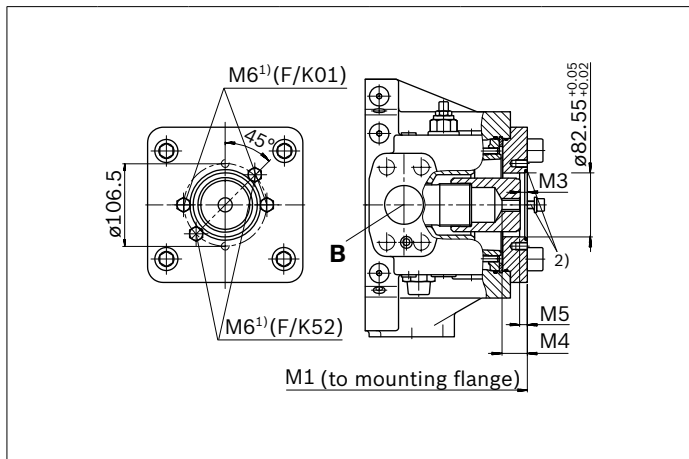

<b>01</b>	<b>NG</b>	<b>M1</b>	<b>M3</b>	<b>M4</b>	<b>M5</b>	<b>M6</b>
<b>250</b>		531	10.5	33	10	M10; 15 deep
<b>355</b>		538	10.5	33	10	
<b>500</b>		574	9.3	33	10	
<b>750</b>		641	9.3	33	10	

<b>52</b>	<b>NG</b>	<b>M1</b>	<b>M3</b>	<b>M4</b>	<b>M5</b>	<b>M6</b>
<b>355</b>		531	19.5	40.5	10	M10; 15 deep
<b>500</b>		574	19.5	40.5	10	

▼ **F/K68; F/K04**

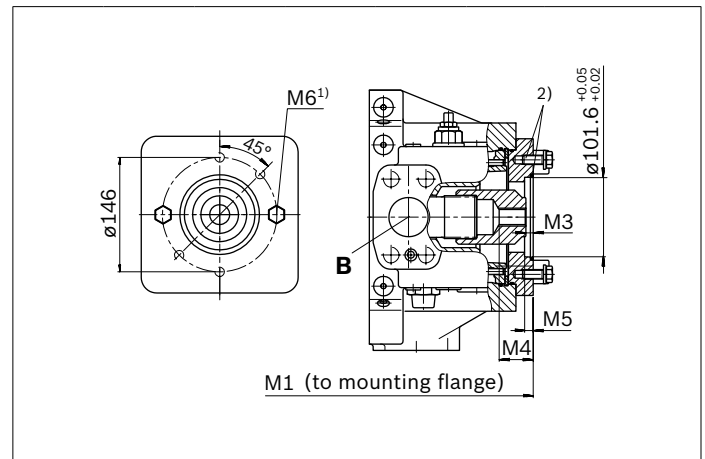

<b>68</b>	<b>NG</b>	<b>M1</b>	<b>M3</b>	<b>M4</b>	<b>M5</b>	<b>M6</b>
<b>250</b>		531	18.5	43.5	10	M12; 15 deep
<b>355</b>		538	18.5	43.5	10	
<b>500</b>		574	18.5	43.5	10	

<b>04</b>	<b>NG</b>	<b>M1</b>	<b>M3</b>	<b>M4</b>	<b>M5</b>	<b>M6</b>
<b>355</b>		538	18.9	48.4	10	M12; 15 deep
<b>500</b>		574	19.4	48.4	10	

1) Thread according to DIN 13, see instruction manual for details on tightening torques

2) 2 mounting bolts and O-ring seal are included in the scope of delivery.

Flange SAE J744 (ISO 3019-1) Diameter	Hub for splined shaft SAE J744	Availability over sizes				Code F/K
		250	355	500	750	
127-2 (C)	1 1/4 in 14T 12/24DP	●	●	●	○	<b>07</b>
127-2 (C)	1 1/2 in 17T 12/24DP	○	●	●	○	<b>24</b>
152-4 (D)	1 3/4 in 13T 8/16DP	●	●	●	●	<b>17</b>

● = Available    ○ = On request

▼ **F/K07; F/K24**

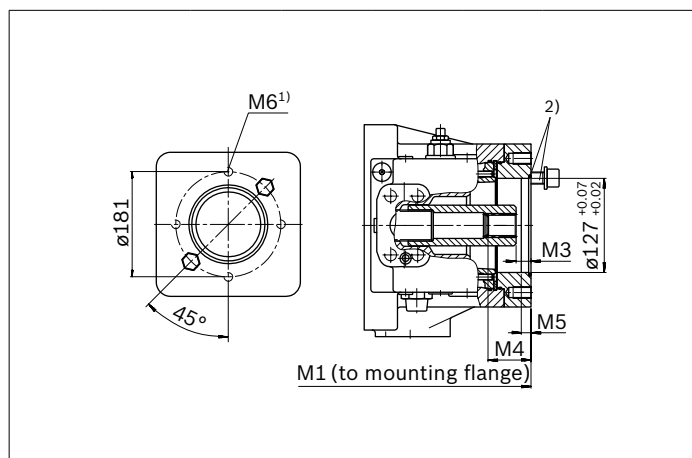

▼ **F/K17**

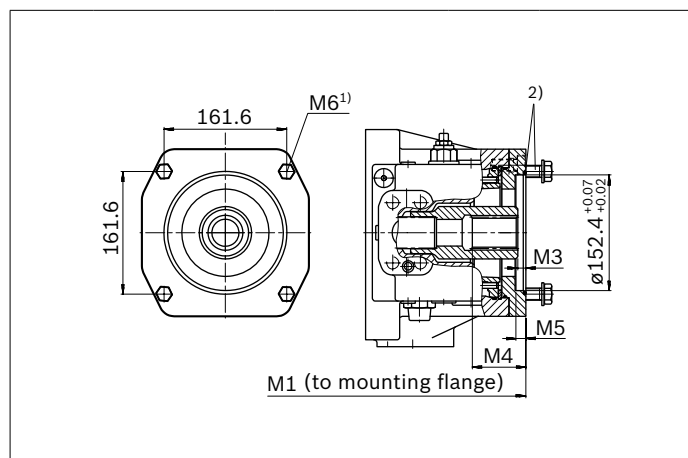

07	NG	M1	M3	M4	M5	M6
250	545	19.9	58	13	M16; 24 deep	
355	552	19.9	58	13	M16; 24 deep	
500	588	18.3	58	13	M16; 24 deep	

17	NG	M1	M3	M4	M5	M6
250	531	10.4	73	13	M16; 22 deep	
355	538	10.4	73	13	M16; 22 deep	
500	600	10.4	73	13	M16; 32 deep	
750	667	10.4	73	13	M16; 32 deep	

24	NG	M1	M3	M4	M5	M6
250	545	10.4	75	13	M16; 24 deep	
355	552	10.4	75	13	M16; 24 deep	
500	588	10.3	67	13	M16; 24 deep	

1) Thread according to DIN 13, see instruction manual for details on tightening torques  
2) 2 mounting bolts and O-ring seal are included in the scope of delivery.

3) 4 mounting bolts and O-ring seal are included in the scope of delivery.

## Integrated boost pump and valve technology (version F..)

### High-pressure relief valve (Pos. 5)

Two pilot-operated pressure relief valves use pressure limitation to prevent damage to the hydraulic pump resulting from overpressure. A pressure relief valve is assigned to each pressure side.

Protection is provided by reducing the high pressure to the low pressure side.

Pressure limitation is set by default to 350 bar. If another setting is required, please state this in plain text.

### Boost-pressure relief valve (Pos. 3)

direct operated

The boost pressure can be set on the boost-pressure relief valve.

### Boost pressure

To prevent damage to the system, low pressure monitoring is recommended, which monitors the static pressure component. The ports **M<sub>E3</sub>** or **M<sub>K4</sub>**, for example, are suitable for low pressure monitoring. To prevent any impermissible drop in boost pressure, Bosch Rexroth recommends connecting a low pressure accumulator to the ports **E<sub>2</sub>**, **E<sub>3</sub>** or **K<sub>4</sub>**. The design of the accumulator and the choice of the optimum connection location must be selected according to the hydraulic transmission behavior of the system and the operating conditions, taking the available boost volume into account. Depending on the quantity of system case drain fluid, it may be necessary to increase the boost volume with a larger or additional boost pump.

### Integrated boost pump (Pos. 9)

Standard size

NG	250	355	500	750
cm <sup>3</sup>	63 <sup>1)</sup>	80 <sup>1)</sup>	98	143

### Control pressure relief valve (for EP and HD) (Pos. 8)

Direct operated, high-pressure-related relief

At low working pressure, the auxiliary pump pressure is regulated to the set value (e.g. 32 bar). This pressure is needed by the HD and EP controls to swivel out reliably. Using this valve saves the use of a separate control pressure pump.

If the working pressure exceeds the pressure of the boost pump, control is provided by the check valve via the high pressure. At the same time, the increase in working pressure relieves the control pressure relief valve.

The boost pump pressure is hereby reduced to the set boost pressure (e.g. 16 bar).

This function leads to energy savings, improved efficiency and a longer service life of the auxiliary pump.

For setting values, see page 6.

The control pressure relief valve is not required for the other control devices and is replaced with a threaded plug.

### Control fluid filter (Pos. 10)

The HD and EP controls of the sizes 500 and 750 with internal control pressure supply from the high pressure are equipped with 0.2 mm coarse dirt filters as standard (regardless of the filtration order designation)

The dimensions are as show on pages 12 to 19. See circuit diagram on page 29.

### Flushing valve (Pos. 4)

To open the flushing valve safely, the pressure differential between **A** and **B** is required, as shown in the diagram. The required pressure differential depends on the rotational speed and the size. The circuit temperature needs to be monitored to avoid any damage to the system.

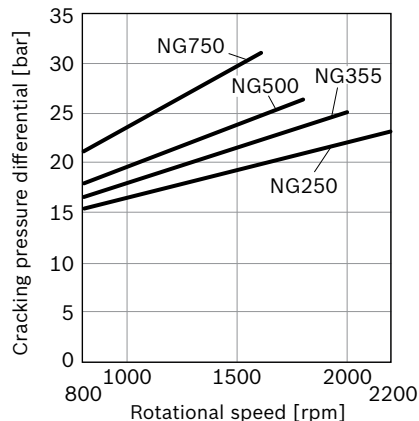

1) Larger boost pumps available on request

## ▼ Circuit diagram

**Example: A4CSG...EPG...F..4N (without filter)**

Sizes 500 and 750. Additional sizes available on request.

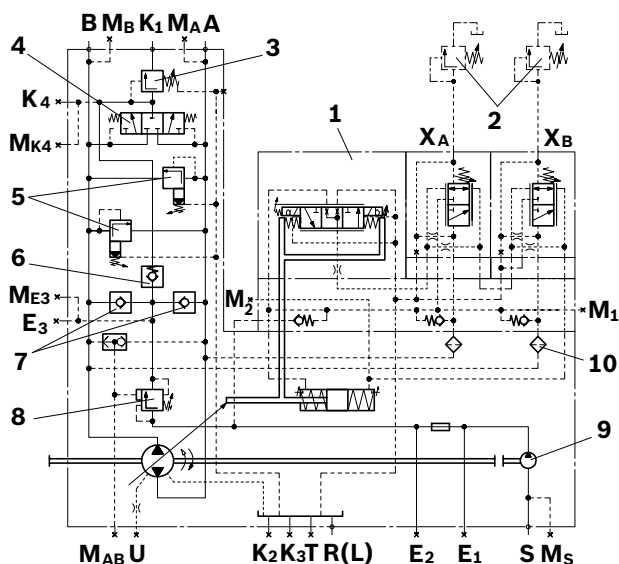
**Components**

- |           |  |
|-----------|--|
| <b>1</b>  | EPG control  |
| <b>2</b>  | Pressure relief valves (not included in the scope of delivery) |
| <b>3</b>  | Boost-pressure relief valve                                    |
| <b>4</b>  | Flushing valve   |
| <b>5</b>  | High-pressure relief valves                                    |
| <b>6</b>  | Bypass valve   |
| <b>7</b>  | Boost check valves   |
| <b>8</b>  | Control pressure relief valve                                  |
| <b>9</b>  | Integrated boost pump  |
| <b>10</b> | Control fluid filter for HD and EP (sizes 500 and 750)         |

**Circuit diagram NG 500/750 with filter**, see page 32;  
**without** integrated boost pump, see page 30

Ports		$P_{max}$ [bar]	State
<b>A, B</b>	Working line (pressure port)	400	O
<b>S</b>	Suction port	30	O
<b>M<sub>A</sub>, M<sub>B</sub>, M<sub>AB</sub></b>	Measuring working pressure A/B	400	X
<b>M<sub>S</sub></b>	Measuring suction	30	X
<b>T</b>	Fluid drain	4	X
<b>E<sub>1</sub></b>	Filter, supply	40	X
<b>E<sub>2</sub></b>	Filter, return	40	X
<b>K<sub>1</sub></b>	Flushing port	5	O
<b>K<sub>2</sub>, K<sub>3</sub></b>	Fluid filling + air bleeding	4	X
<b>R(L)</b>	Return flow (drain port)	4	O
<b>U</b>	Bearing flushing	7	X
<b>E<sub>3</sub></b>	Boost pressure supply	40	X
<b>M<sub>E3</sub></b>	Measuring boost pressure	40	X
<b>K<sub>4</sub></b>	Accumulator port	40	X
<b>M<sub>K4</sub></b>	Measuring boost pressure	40	X
<b>M<sub>1</sub></b>	Measuring stroking chamber pressure	400	X
<b>M<sub>2</sub></b>	Measuring stroking chamber pressure	400	X
<b>X<sub>A</sub>, X<sub>B</sub></b>	Pilot pressure, remote control pressure controller	350	O

## External boost pressure supply

### Without integrated boost pump (version K..)

Port **E** (or **E<sub>2</sub>** for version K...N/D without filter) is intended as an external boost pressure supply and must be connected. To ensure functional reliability, maintain the required cleanliness level for the boost fluid fed in at port **E/E<sub>2</sub>** (see page 5), and observe the boost pressure values (see page 6).

### Dimensions, size 500

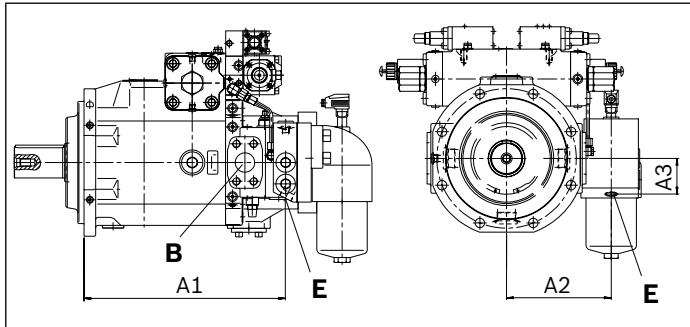

For the location and dimensions of the port **E<sub>2</sub>**, see page 31

NG	A1	A2	A3	Port E	Standard
250	477	270	92	M33 × 2; 18 deep	DIN 3852
355	484	270	92	M33 × 2; 18 deep	DIN 3852
500	520	270	92	M33 × 2; 18 deep	DIN 3852
750	585	270	92	M33 × 2; 18 deep	DIN 3852

Ports		$P_{max}$ [bar]	State
<b>E</b>	Boost pressure supply for version with filter	40	○
<b>E<sub>2</sub></b>	Boost pressure supply for version without filter	40	○
<b>A, B</b>	Working line (pressure port)	400	○
<b>S</b>	Suction port (only for version F)	30	○
<b>M<sub>A</sub>, M<sub>B</sub>, M<sub>AB</sub></b>	Measuring working pressure A/B	400	X
<b>M<sub>S</sub></b>	Measuring suction	30	X
<b>T</b>	Fluid drain	4	X
<b>E<sub>1</sub></b>	Filter, supply	40	X
<b>E<sub>2</sub></b>	Filter, return (for version with filter)	40	X
<b>K<sub>1</sub></b>	Flushing port	5	○
<b>K<sub>2</sub>, K<sub>3</sub></b>	Fluid filling + air bleeding	4	X
<b>R(L)</b>	Return flow (drain port)	4	○
<b>U</b>	Bearing flushing	7	X
<b>E<sub>3</sub></b>	Boost pressure supply	40	X
<b>M<sub>E3</sub></b>	Measuring boost pressure	40	X
<b>K<sub>4</sub></b>	Accumulator port	40	X
<b>M<sub>K4</sub></b>	Measuring boost pressure	40	X
<b>M<sub>1</sub></b>	Measuring stroking chamber pressure	400	X
<b>M<sub>2</sub></b>	Measuring stroking chamber pressure	400	X

### Circuit diagram

#### Example: A4CSG...EPD...K..4M

Sizes 500 and 750. Additional sizes available on request.

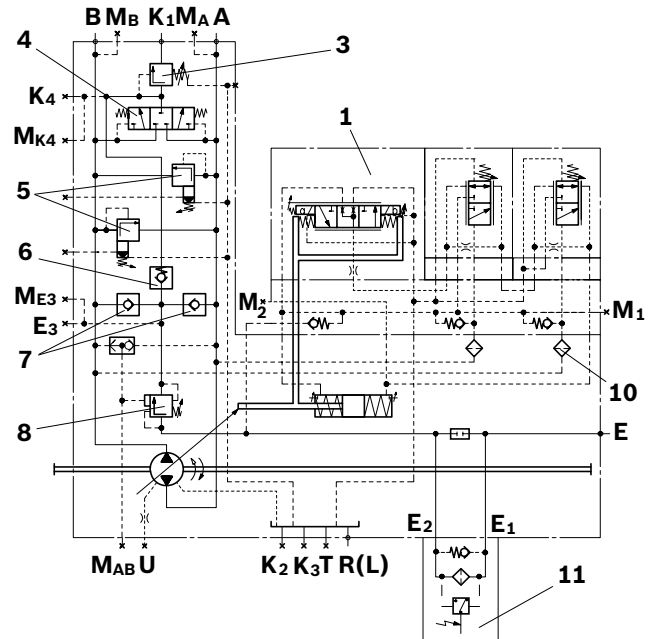

### Components

- 1** EP control
- 3** Boost-pressure relief valve
- 4** Flushing valve
- 5** High-pressure relief valves
- 6** Bypass valve
- 7** Boost check valves
- 8** Control pressure relief valve
- 10** Control fluid filter for HD and EP (sizes 500 and 750)
- 11** Filter with bypass

### Filtration types<sup>1)</sup>

Regardless of the selected boost circuit filtration, the HD and EP controls in sizes 500 and 750 are equipped with 0.2 mm control fluid coarse dirt filters as standard (see circuit diagram).

#### Without filter in the boost circuit (version N)

Ports E<sub>1</sub> and E<sub>2</sub> are delivered plugged, pressure-proof and internally connected.

A boost circuit filter can be connected to these ports later on.

The internal passage between E<sub>1</sub> and E<sub>2</sub> must be plugged for this purpose (please contact us).

For unit dimensions, see pages 12 to 19.

See circuit diagram on page 29.

#### Ports for external boost circuit filtration (version D)

Ports E<sub>1</sub> and E<sub>2</sub> are intended for a filter port.

These ports are open and are only plugged with plastic screws for transportation.

The internal passage between E<sub>1</sub> and E<sub>2</sub> is plugged.

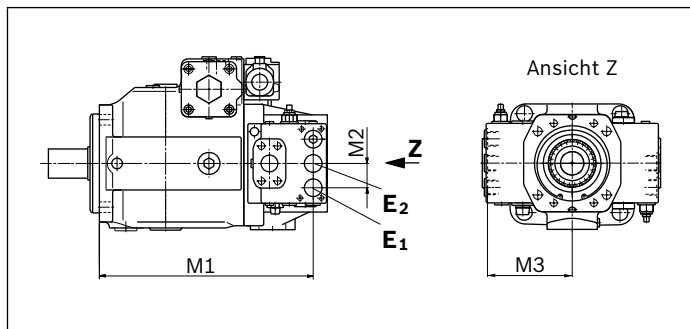

NG	M1	M2	M3	Port E1/E2	Standard
250	477	55	193	M33 × 2; 18 deep	DIN 3852
355	484	55	193	M33 × 2; 18 deep	DIN 3852
500	520	55	193	M33 × 2; 18 deep	DIN 3852
750	585	55	194	M33 × 2; 18 deep	DIN 3852

Ports		p <sub>max</sub> [bar]	State
E <sub>1</sub>	Filter, supply	50	○
E <sub>2</sub>	Filter, return	50	○

### Circuit diagram<sup>1)</sup>

#### Example: A4CSG...EPD...F..4D

Sizes 500 and 750. Additional sizes available on request.

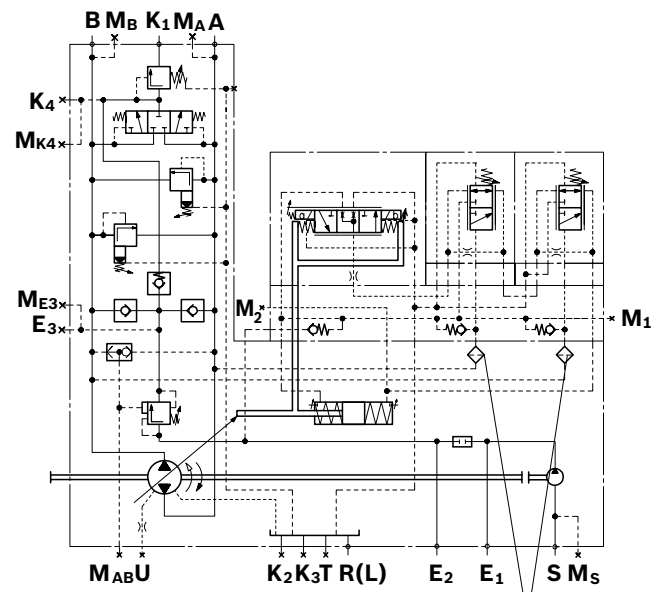

Control fluid filter for HD and EP (sizes 500 and 750)

1) For components and ports, see page 30

**With mounted filter in the boost circuit (version M)**

A filter is mounted directly on the pump in the pressure line of the boost pump, thus plugging the internal connection between E1 and E2.

Filter version: Type DFBN/HC330QE10D1.X/V-L24

Filter with bypass and visual-electrical contamination indicator

Response pressure of the contamination indicator

$\Delta p_a = 5 \text{ bar} - 0.5 \text{ bar}$

Cracking pressure of the bypass valve  $\Delta p_{\delta} = 6 \text{ bar} + 0.6 \text{ bar}$

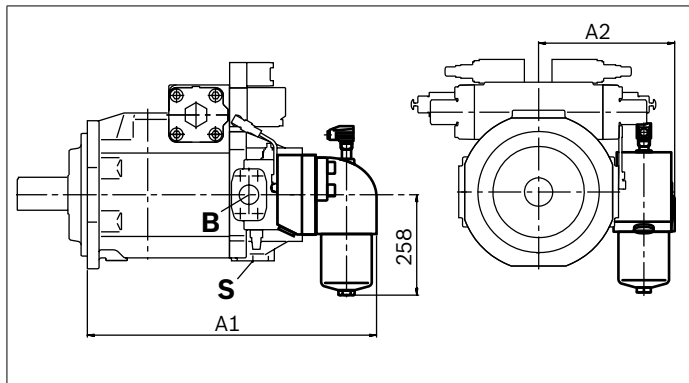

Size	A1	A2
250	699.5	200
355	706.5	347
500	742.5	
750		

Ports		$p_{\max}$ [bar]	State
<b>A, B</b>	Working line (pressure port)	400	O
<b>S</b>	Suction port	30	O
<b>M<sub>A</sub>, M<sub>B</sub>, M<sub>AB</sub></b>	Measuring working pressure A/B	400	X
<b>M<sub>S</sub></b>	Measuring suction	30	X
<b>T</b>	Fluid drain	4	X
<b>E<sub>1</sub></b>	Filter, supply	50	X
<b>E<sub>2</sub></b>	Filter, return	50	X
<b>K<sub>1</sub></b>	Flushing port	5	O
<b>K<sub>2</sub>, K<sub>3</sub></b>	Fluid filling + air bleeding	4	X
<b>R(L)</b>	Return flow (drain port)	4	O
<b>U</b>	Bearing flushing	7	X
<b>E<sub>3</sub></b>	Boost pressure supply	40	X
<b>M<sub>E3</sub></b>	Measuring boost pressure	40	X
<b>K<sub>4</sub></b>	Accumulator port	40	X
<b>M<sub>K4</sub></b>	Measuring boost pressure	40	X
<b>M<sub>1</sub></b>	Measuring stroking chamber pressure	400	X
<b>M<sub>2</sub></b>	Measuring stroking chamber pressure	400	X

**Example: A4CSG...EPD...F.4M**

Sizes 250 and 355. Additional sizes available on request.

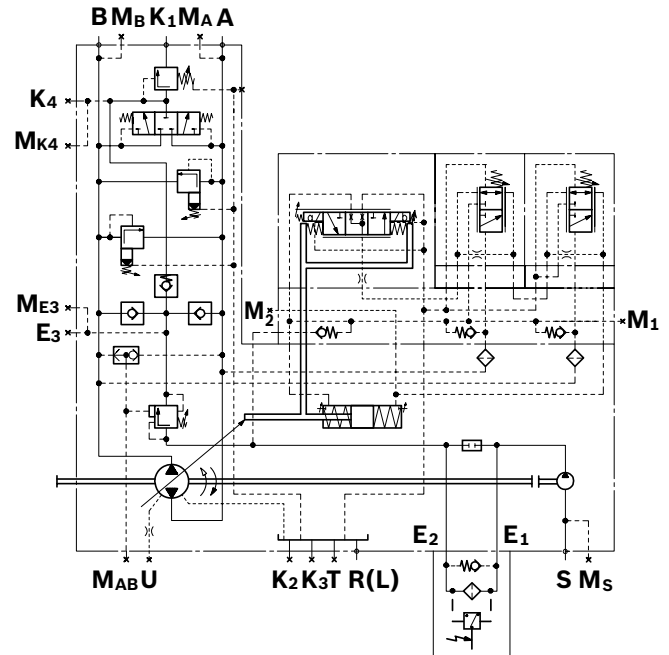



## Installation instructions

### General

The axial piston unit must be filled with hydraulic fluid and air bled during commissioning and operation. This must also be observed following a longer standstill as the axial piston unit may empty via the hydraulic lines.

With particular regard to the “drive shaft upwards” installation position, we recommend bearing flushing to lubricate the front bearing and shaft seal at port **U**. See page 5.

The leakage in the housing area must be directed to the reservoir via the highest drain port (**T**, **R(L)**, **K<sub>2</sub>**, **K<sub>3</sub>**).

If a shared drain line is used for several units, make sure that the respective case pressure is not exceeded. The shared drain line must be dimensioned to ensure that the maximum permissible case pressure of all connected units is not exceeded in any operational conditions, particularly at cold start. If this is not possible, separate reservoir lines must be installed if necessary.

To achieve favorable noise values, decouple all connecting lines using elastic elements and avoid above-reservoir installation.

In all operating conditions, the suction lines and the drain lines must flow into the reservoir below the minimum fluid level. The permissible suction height  $h_s$  results from the overall loss of pressure, it must not, however, be higher than  $h_{s\ max} = 800\ \text{mm}$ . The minimum suction pressure at port **S** must also not fall below 0.8 bar absolute during operation.

For external boost pressure supply (version **K..**) please refer to the attachment pump data sheet for details on the minimum suction pressure.

When designing the reservoir, ensure that there is adequate spacing between the suction line and the drain line. This minimizes oil turbulence and carries out degassing, which prevents the heated hydraulic fluid from being sucked directly back in again.

### Installation position

See the following examples **1** to **8**.

Further installation positions are available upon request.

Recommended installation position: **1st**

#### Notice

- ▶ To achieve an optimum control function, the stroking chambers must be air bled via the highest air bleed port **R2** to **R7** depending on the installation positions for HS5 and EO.
- ▶ You can expect installation positions **2**, **3**, **6** and **7** to affect the closed loop control. Due to gravity, dead weight and case pressure, minor characteristic shifts and actuating time changes may occur.

#### Key

<b>S</b>	Suction port
<b>T, K<sub>2</sub>, K<sub>3</sub>, R(L)</b>	Fluid filling + air bleeding (drain port)
<b>A, B</b>	Pressure port
<b>U</b>	Bearing flushing port
<b>SB</b>	Baffle (baffle plate)
<b><math>h_{t\ min}</math></b>	Minimum required immersion depth (200 mm)
<b><math>h_{min}</math></b>	Minimum required distance to the reservoir bottom (100 mm)
<b><math>h_{s\ max}</math></b>	Maximum permissible suction height 800 mm for version F. For version K, observe the external boost pump specification.

**Below-reservoir installation (recommended)**

Below-reservoir installation means that the axial piston unit is installed outside of the reservoir and below the minimum fluid level of the reservoir.

Installation position	Air bleeding <sup>1)</sup>	Filling
<b>1</b>	<b>R(L)</b>	<b>R(L)</b>

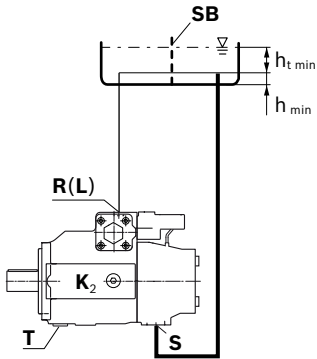

<b>2</b>	<b>K<sub>2</sub>; R(L) plug</b>	<b>K<sub>2</sub></b>
----------	---------------------------------	----------------------

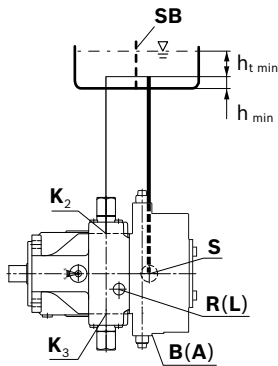

Installation position	Air bleeding <sup>1)</sup>	Filling
<b>3</b>	<b>K<sub>3</sub>; R(L) plug</b>	<b>K<sub>3</sub></b>

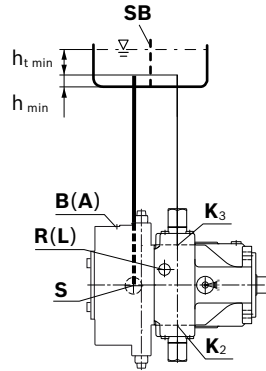

<b>4</b>	<b>T; R(L) plug</b>	<b>T</b>
----------	---------------------	----------

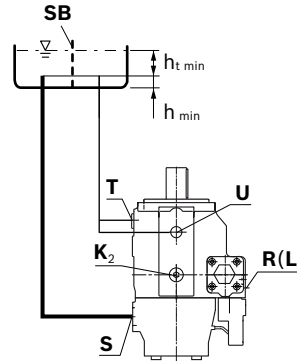

Key, see page 33.

1) To air bleed the stroking chamber, use the highest port on the control (see control data sheet)

**Above-reservoir installation**

Above-reservoir installation means that the axial piston unit is installed above the minimum fluid level of the reservoir. A check valve in the drain line is to be avoided. Exceptions may be permissible, please consult us first.

Installation position	Air bleeding <sup>1)</sup>	Filling
5	R(L)	R(L)

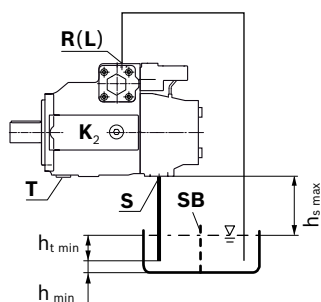

Installation position	Air bleeding <sup>1)</sup>	Filling
7	K <sub>3</sub> ; R(L) plug	K <sub>3</sub>

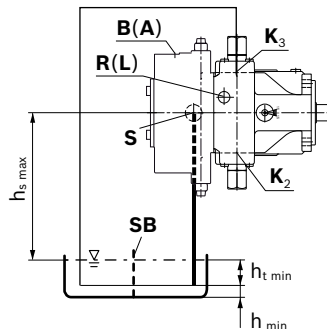

6	K <sub>2</sub> ; R(L) plug	K <sub>2</sub>
---	----------------------------	----------------

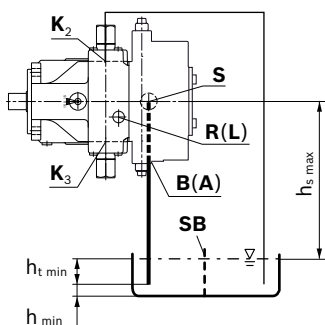

8	T; R(L) plug	T
---	--------------	---

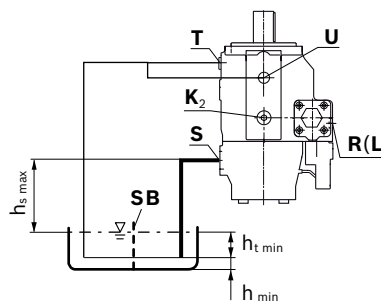

Key, see page 33.

<sup>1)</sup> To air bleed the stroking chamber, use the highest port on the control (see control data sheet)

## Project planning notes

- ▶ The pump A4CSG is designed to be used in closed circuit.
- ▶ The project planning, installation and commissioning of the axial piston unit requires the involvement of qualified skilled personnel.
- ▶ Before using the axial piston unit, please read the corresponding instruction manual completely and thoroughly. If necessary, this can be requested from Bosch Rexroth.
- ▶ Before finalizing your design, please request a binding installation drawing.
- ▶ The specified data and notes contained herein must be observed.
- ▶ Preservation: Our axial piston units are supplied as standard with preservative protection for a maximum of 12 months. If longer preservative protection is required (maximum 24 months), please specify this in plain text when placing your order. The preservation periods apply under optimal storage conditions, details of which can be found in the data sheet 90312 or in the instruction manual.
- ▶ Depending on the operating conditions of the axial piston unit (working pressure, fluid temperature), the characteristic curve may shift.
- ▶ Not all versions of the product are approved for use in a safety function according to ISO 13849. Please consult the responsible contact person at Bosch Rexroth if you require reliability parameters (e.g.  $MTTF_d$ ) for functional safety.
- ▶ Pressure controllers are not safeguards against pressure overload. Be sure to add a pressure relief valve to the hydraulic system.
- ▶ Working ports:
  - The ports and fastening threads are designed for the specified maximum pressure. The machine or system manufacturer must ensure that the connecting elements and lines correspond to the specified application conditions (pressure, flow, hydraulic fluid, temperature) with the necessary safety factors.
  - The working ports and function ports are only intended to accommodate hydraulic lines.

## Safety instructions

- ▶ During and shortly after operation, there is a risk of getting burnt on the axial piston unit and especially on the solenoids. Take the appropriate safety measures (e.g. by wearing protective clothing).
- ▶ Moving parts in control equipment (e.g. valve spools) can, under certain circumstances, get stuck in position as a result of contamination (e.g. impure hydraulic fluid, abrasion, or residual dirt from components). As a result, the hydraulic fluid flow and the build-up of torque in the axial piston unit can no longer respond correctly to the operator's specifications. Even the use of various filter elements (external or internal flow filtration) will not rule out a fault but merely reduce the risk. The machine/system manufacturer must test whether remedial measures are needed on the machine for the application concerned in order to bring the driven consumer into a safe position (e.g. safe stop) and ensure any measures are properly implemented.



**Bosch Rexroth AG**  
Mobile Applications  
An den Kelterwiesen 14  
72160 Horb a. N., Germany  
Tel. +49 7451 92-0  
info.ma@boschrexroth.de  
www.boschrexroth.com/brm

© Bosch Rexroth AG 2016. All rights reserved, also regarding any disposal, exploitation, reproduction, editing, distribution, as well as in the event of applications for industrial property rights. The data specified within only serves to describe the product. No statements concerning a certain condition or suitability for a certain application can be derived from our information. The information given does not release the user from the obligation of own judgment and verification. It must be remembered that our products are subject to a natural process of wear and aging.